

JVC

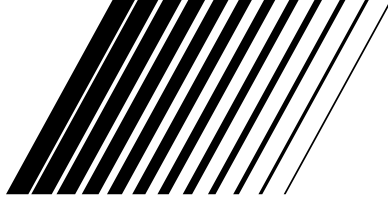

CD PORTABLE SYSTEM

RC-EX25S

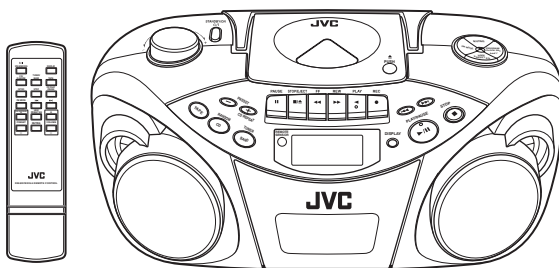

COMPACT
disc
DIGITAL AUDIO

INSTRUCTIONS

LVT1212-003A
[B]

Warnings, Cautions and Others

IMPORTANT for the U.K.

DO NOT cut off the mains plug from this equipment. If the plug fitted is not suitable for the power points in your home or the cable is too short to reach a power point, then obtain an appropriate safety approved extension lead or consult your dealer.

BE SURE to replace the fuse only with an identical approved type, as originally fitted.

If nonetheless the mains plug is cut off ensure to remove the fuse and dispose of the plug immediately, to avoid a possible shock hazard by inadvertent connection to the mains supply.

If this product is not supplied fitted with a mains plug then follow the instructions given below:

IMPORTANT:

DO NOT make any connection to the terminal which is marked with the letter E or by the safety earth symbol or coloured green or green-and-yellow.

The wires in the mains lead on this product are coloured in accordance with the following code:

Blue : Neutral

Brown : Live

As these colours may not correspond with the coloured markings identifying the terminals in your plug proceed as follows:

The wire which is coloured blue must be connected to the terminal which is marked with the letter N or coloured black.

The wire which is coloured brown must be connected to the terminal which is marked with the letter L or coloured red.

IF IN DOUBT - CONSULT A COMPETENT ELECTRICIAN.

Caution — STANDBY/ON button!

Disconnect the mains plug to shut the power off completely. The STANDBY/ON button in any position does not disconnect the mains line.

CAUTION

To reduce the risk of electrical shocks, fire, etc.:

1. Do not remove screws, covers or cabinet.
2. Do not expose this appliance to rain or moisture.

Caution: Proper Ventilation

To avoid risk of electric shock and fire, and to prevent damage, locate the apparatus as follows:

- 1 Front:
No obstructions and open spacing.
- 2 Sides/ Top/ Back:
No obstructions should be placed in the areas shown by the dimensions below.
- 3 Bottom:
Place on the level surface. Maintain an adequate air path for ventilation by placing on a stand with a height of 10 cm or more.

Front view

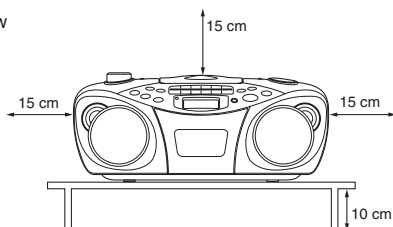

Side view

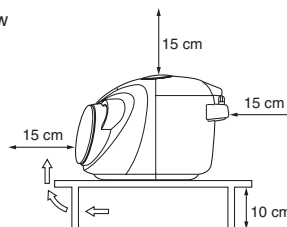

IMPORTANT FOR LASER PRODUCTS

1. CLASS 1 LASER PRODUCT
2. **CAUTION:** Do not open the top cover. There are no user serviceable parts inside the unit; leave all servicing to qualified service personnel.
3. **CAUTION:** Visible and invisible laser radiation when open and interlock failed or defeated. Avoid direct exposure to beam.
4. **REPRODUCTION OF LABEL:** CAUTION LABEL, PLACED INSIDE THE UNIT.

CAUTION - INVISIBLE LASER RADIATION WHEN OPEN AND INTERLOCKS DEFEATED. AVOID EXPOSURE TO BEAM.

VORSICHT ! UNSICHTBARE LASERSTRAHLUNG TRITTS AUS, WENN DECKEL GEÖFFNET UND WENN SICHERHEITVERRIEGELUNG ÜBERBRÜCKT IST. NICHT DEM STRAHL AUSSETZEN!

WARNING - OSYNLIG LASERSTRÅLNING NÄR DENNA DEL ÄR ÖPPNAD OCH SPÄRR ÄR URKOPPLAD STRÅLEN ÄR FARLIG.

ADVARSEL - USYNLIG LASERSTRÅLING VED ÅBNING NÅR SIKKERHEDSAFBRYDERE ER UDE AF FUNKTION. UNDGÅ UDSÆTTELSE FOR STRÅLING.

CAUTION

- Do not block the ventilation openings or holes. (If the ventilation openings or holes are blocked by a newspaper or cloth, etc., the heat may not be able to get out.)
- Do not place any naked flame sources, such as lighted candles, on the apparatus.
- When discarding batteries, environmental problems must be considered and local rules or laws governing the disposal of these batteries must be followed strictly.
- Do not expose this apparatus to rain, moisture, dripping or splashing and that no objects filled with liquids, such as vases, shall be placed on the apparatus.

SAFETY INSTRUCTIONS

“SOME DOS AND DON'TS ON THE SAFE USE OF EQUIPMENT”

This equipment has been designed and manufactured to meet international safety standards but, like any electrical equipment, care must be taken if you are to obtain the best results and safety is to be assured.

Do read the operating instructions before you attempt to use the equipment.

Do ensure that all electrical connections (including the mains plug, extension leads and interconnections between pieces of equipment) are properly made and in accordance with the manufacturer's instructions. Switch off and withdraw the mains plug when making or changing connections.

Do consult your dealer if you are ever in doubt about the installation, operation or safety of your equipment.

Do be careful with glass panels or doors on equipment.

DON'T continue to operate the equipment if you are in any doubt about it working normally, or if it is damaged in any way — switch off, withdraw the mains plug and consult your dealer.

DON'T remove any fixed cover as this may expose dangerous voltages.

DON'T leave equipment switched on when it is unattended unless it is specifically stated that it is designed for unattended operation or has a standby mode.

Switch off using the switch on the equipment and make sure that your family know how to do this.

Special arrangements may need to be made for infirm or handicapped people.

DON'T use equipment such as personal stereos or radios so that you are distracted from the requirements of traffic safety. It is illegal to watch television whilst driving.

DON'T listen to headphones at high volume as such use can permanently damage your hearing.

DON'T obstruct the ventilation of the equipment, for example with curtains or soft furnishings.

Overheating will cause damage and shorten the life of the equipment.

DON'T use makeshift stands and NEVER fix legs with wood screws — to ensure complete safety always fit the manufacturer's approved stand or legs with the fixings provided according to the instructions.

DON'T allow electrical equipment to be exposed to rain or moisture.

ABOVE ALL

- NEVER let anyone, especially children, push anything into holes, slots or any other opening in the case — this could result in a fatal electrical shock.
- NEVER guess or take chances with electrical equipment of any kind — it is better to be safe than sorry!

CONTENTS

FEATURES	1	ADJUSTING THE SOUND	8
SAFETY PRECAUTIONS	1	PLAYING COMPACT DISCS	9
HANDLING PRECAUTIONS	2	RADIO RECEPTION	14
POWER SUPPLY	3	CASSETTE PLAYBACK	16
NAMES OF PARTS AND CONTROLS	4	RECORDING	18
REMOTE CONTROL UNIT	5	MAINTENANCE	20
TURNING THE UNIT ON/OFF	6	TROUBLESHOOTING	21
SETTING THE CLOCK	7	SPECIFICATIONS	22

FEATURES

- 1 Portable system incorporating CD player**
 - CD functions can be operated with the remote control unit as well as on the main unit.
 - 8-cm CD playback capability
- 2 Digital LCD (Liquid Crystal Display) indicates general playback status.**
- 3 Synchronized recording with CD playback**
- 4 Hyper-Bass Sound effect**

SAFETY PRECAUTIONS

Prevention of Electric Shocks, Fire Hazards and Damages

- Even when the STANDBY/ON button is set to STANDBY, a very small current will flow. When the unit is turned on, the display window lights in orange. When the unit is in standby mode, the display window turns off. (Note, however, that the display window does not light even when the unit is turned on if the unit is operated on batteries.) To save power and for safety when not using the unit for an extended period of time, disconnect the power cord from the household AC outlet.
- Do not handle the power cord with wet hands.
- When unplugging from the wall outlet, always grasp and pull the plug, not the power cord.
- Consult your nearest dealer when damage, disconnection, or contact failure is found with the cord.
- Do not bend the cord sharply, or pull or twist it.
- Rating label is placed on the exterior of the bottom.
- Do not modify the power cord in any manner.
- Do not remove screws to disassemble the unit and do not touch anything inside the unit to avoid accidents.
- Do not insert any metallic objects into the unit.
- Unplug the power cord when there is a possibility of lightning.
- If water gets inside the unit, unplug the power cord from the outlet and consult your dealer.
- Do not block the ventilation holes of the unit so that heat can escape.
- Do not install the unit in a badly ventilated place.

HANDLING PRECAUTIONS

Do not use this unit in direct sunlight or leave the unit in a closed automobile (or yacht, etc.) where it would be exposed to high temperatures above 40°C.

1 Avoid using the unit in the following places:

- Where the temperature may become excessively high or low; the recommended temperature range is 5°C and 35°C.
- Where it could be subject to vibrations.
- Where it is excessively humid, such as in a bathroom.
- Where it could be magnetized by a magnet or speaker.

2 Pay attention to dust.

Be sure to close the disc door so that the lens is not contaminated by dust. Do not touch the lens.

3 Condensation

Condensation may occur in the following cases, in which the unit may not operate correctly:

- The unit is in a room where a heater has just been switched on.
- The unit is in a place where there is smoke or high humidity.
- The unit has just moved from a cold place to a warm room.

In these cases, set the STANDBY/ON button to ON and wait one or two hours before use.

4 Volume control

Compact discs produce very little noise compared with analog records. If you adjust the volume by listening to the noise as you do with analog records, the speakers could be damaged by a sudden blast of sound when playback starts. Therefore, turn down the volume before starting and adjust it as required while playing a CD.

5 Safety mechanism

The unit incorporates a safety interlock mechanism which switches off the laser beam when the disc door is opened.

6 Do not place magnetic objects such as cassette tapes near the speakers.

Since the speakers contain magnets inside, do not place cassette tapes or magnetic cards nearby as recorded data could be erased.

7 Keep the unit away from the TV.

When the unit is used near a TV, the TV picture could be distorted. If this happens, move the unit away from the TV. If this does not correct the situation, avoid using the unit when the TV is turned on.

8 Cleaning the cabinet

If the cabinet gets dirty, wipe it with a soft, dry cloth. Never use benzine or thinner as these could damage the surface finish.

9 When listening with headphones

- Do not listen at high volumes as it could damage your hearing.
- For safety, do not drive while listening with headphones.

10 Carrying handle

Do not raise or lower the carrying handle with the telescopic antenna extended, to avoid damaging the antenna. Position the carrying handle so that it does not interfere with operation.

POWER SUPPLY

Operation on household AC

Connect the AC power cord.



CAUTIONS:

- Use only with the JVC power cord provided with this unit to avoid malfunction or damage to the unit. Remove batteries when using the power cord.
- Be sure to unplug the power cord from the outlet when going out or when the unit is not in use for an extended period of time.

Operation on batteries

Loading batteries

1 Open the battery cover.

Pull the battery cover toward you while pressing the sections marked by the arrows.

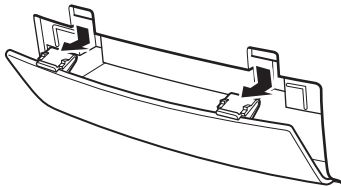

2 Insert six R20 (SUM-1)/D (13D)-size batteries.

Be sure to insert the batteries with the \oplus and \ominus terminals positioned correctly.

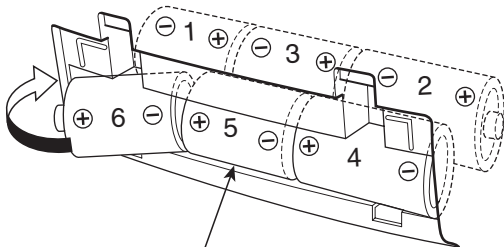

R20 (SUM-1)/D (13D)-size batteries

3 Replace the cover.

Checking batteries

When the tape speed or output sound level decreases, or CD playback becomes intermittent, replace all batteries with fresh ones.

When making an important recording, use new batteries (preferably alkaline batteries with a longer service life) to avoid any possible failure.

For better battery usage

- Continuous operation of the unit causes the battery power to be consumed quicker than noncontinuous operation.
- Operation of the unit in a cold place causes the battery power to be consumed more quickly than in a warm place.

CAUTIONS:

- When not using the unit for a long time (more than two weeks) or when using the household AC, remove the batteries to avoid a malfunction or damage to the unit.
- When the JVC power cord provided with this unit is connected, the power is automatically switched from the batteries to the household AC even when the batteries are loaded. However, remove the batteries when using the power cord.

CAUTIONS WHEN USING BATTERIES:

When batteries are used incorrectly, it may result in the leakage of chemicals from the batteries or they may explode. The following care should be taken:

- Check that the positive \oplus and negative \ominus terminals of the batteries are positioned correctly and load them as shown in the figure on the left.
- Do not mix new and old batteries together, or mix different types of batteries.
- Do not try to recharge non-rechargeable batteries.
- Remove the batteries when the unit is not to be used for an extended period of time.

If chemicals from the batteries come in contact with your skin, wash them off immediately with water. If chemicals leak onto the unit, clean the unit completely.

NAMES OF PARTS AND CONTROLS

Top and front sides

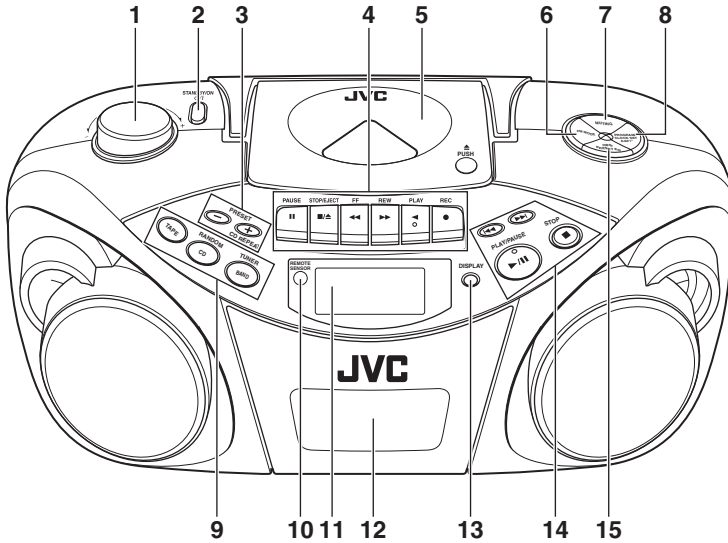

- | | |
|--|---|
| <p>1 VOLUME knob</p> <p>2 STANDBY/ON O/I button</p> <p>3 PRESET – button
PRESET + / CD REPEAT button</p> <p>4 Tape operation buttons
PAUSE II button
STOP/EJECT $\blacksquare/\blacktriangle$ button
FF \lll button
REW \ggg button
PLAY \blacktriangleleft button
REC \bullet button</p> <p>5 Disc door</p> <p>6 FM MODE button</p> <p>7 MUTING button</p> | <p>8 PROGRAM/CLOCK SET button</p> <p>9 TAPE button
CD/RANDOM button
BAND/TUNER button</p> <p>10 REMOTE SENSOR</p> <p>11 Display window</p> <p>12 Cassette deck</p> <p>13 DISPLAY button</p> <p>14 \lll button
\ggg button
PLAY/PAUSE $\blacktriangleright/\text{II}$ button
STOP \blacksquare button</p> <p>15 HBS/PRESET EQ button</p> |
|--|---|

Rear side

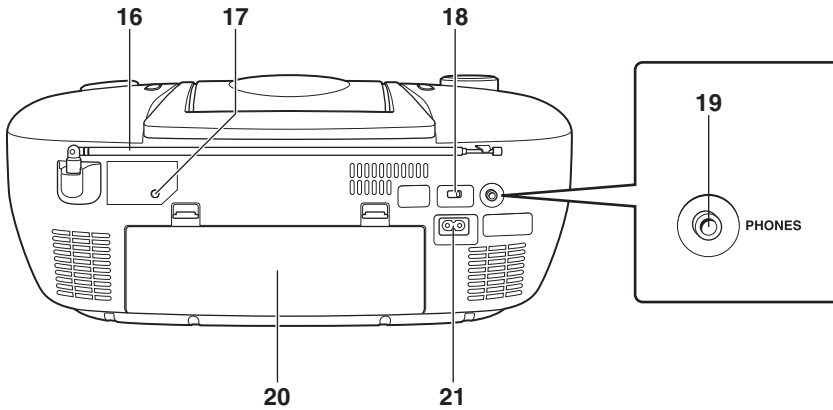

16 Telescopic antenna

17 RESET button

18 BEAT CUT switch

19 PHONES jack

Connect stereo mini headphones (3.5-mm diameters, impedance of 16 Ω to 32 Ω) to this jack. The speaker output is switched off with headphones connected.

20 Battery compartment cover

21 \sim AC IN (AC input) jack

REMOTE CONTROL UNIT

Installing batteries

1 Remove the battery cover from the back of the remote control unit.

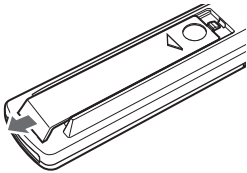

2 Insert two AAA (UM-4)/R03-size batteries (supplied).

Insert the batteries with the \oplus and \ominus terminals matching the indication inside the battery compartment. Insert the \ominus ends first.

AAA (UM-4)/R03-size batteries

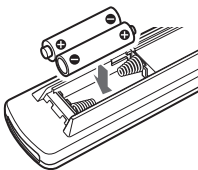

3 Replace the battery cover.

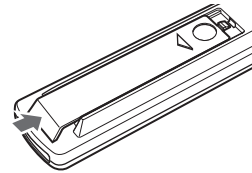

Battery replacement

The maximum operating distance between the remote control unit and the remote sensor section of the unit is approximately 7 meters. When the operating range decreases or remote control operation becomes unstable, replace the batteries with new ones.

Notes on using the remote control unit

- Point the top of the remote control unit toward the remote sensor section of the unit as directly as possible. The operable distance from the main unit decreases if you point the remote control unit at an angle.
- Press the buttons gently and firmly.
- Do not expose the remote sensor section of the unit to strong light (direct sunlight or artificial lighting) and make sure that there are no obstacles between the remote sensor section and the remote control unit.

Names of buttons

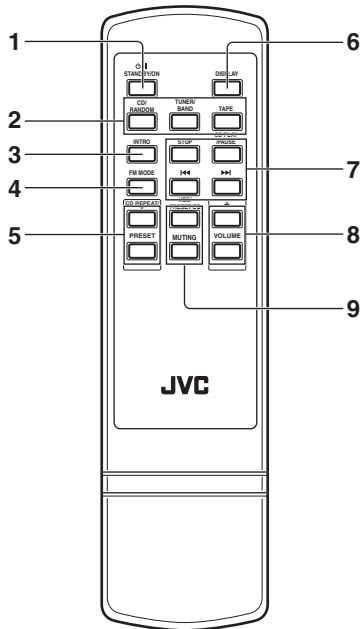

- 1 STANDBY/ON button
- 2 CD/RANDOM button
TUNER/BAND button
TAPE button
- 3 INTRO button
- 4 FM MODE button
- 5 CD REPEAT / PRESET + button
PRESET - button
- 6 DISPLAY button
- 7 STOP button
CD PLAY/PAUSE button
 button
 button
- 8 VOLUME + button
VOLUME - button
- 9 HBS/PRESET EQ button
MUTING button

TURNING THE UNIT ON/OFF

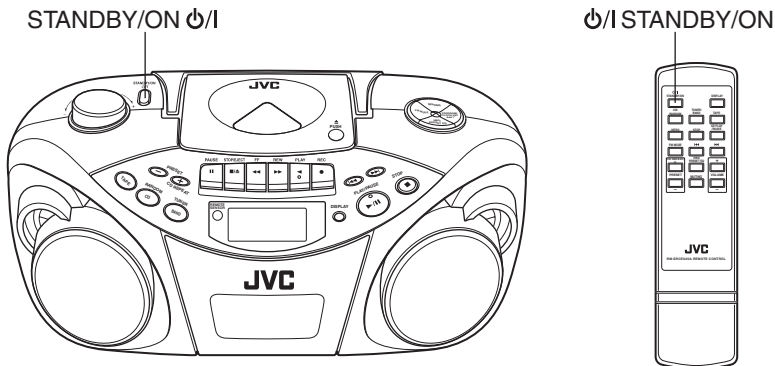

STANDBY/ON



STANDBY/ON button

Press the STANDBY/ON button on the unit to turn on and off the unit.

You can also press the STANDBY/ON button on the remote control unit.

The display window lights up when the unit is turned on. (Note, however, that the display window does not light even when the unit is turned on if the unit is operated on batteries.) The unit comes on ready to play the source selected when the unit was last turned off.

To switch off the power supply completely

Unplug the AC power cord from the AC outlet. If the batteries are inserted in the unit, take them out.

Notes:

- When you unplug the AC power cord or if a power failure occurs, the clock is reset to “0:00” right away, while the tuner preset stations (see page 15) will be erased in a few days. The clock indication will keep flashing until you set the clock again.
- Remove the batteries when carrying the unit by hand or in the trunk of a car. This prevents the power from being accidentally turned on, thus avoiding wasteful battery consumption.

SETTING THE CLOCK

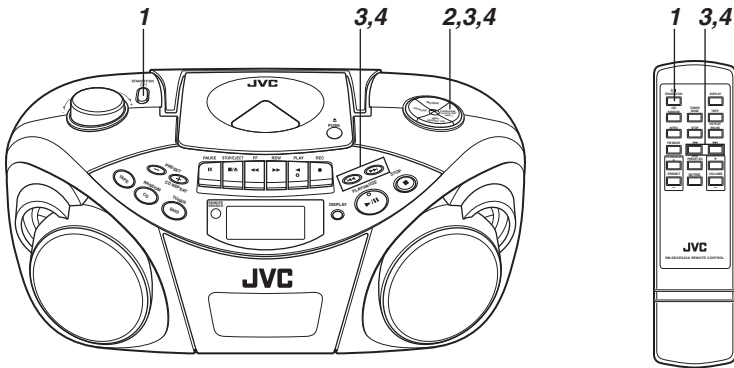

Before operating the unit any further, first set the clock built in this unit.

The clock uses 24-hour indication.

1 Press **STANDBY/ON**  to turn off the unit, if it is turned on.

The clock flashes on the display window.

2 Press and hold **PROGRAM/CLOCK SET** for more than 2 seconds.

The hour digits start flashing.



3 Press **◀◀** or **▶▶** to adjust the hour, then press **PROGRAM/CLOCK SET**.

The minute digits start flashing.



4 Press **◀◀** or **▶▶** to adjust the minutes, then press **PROGRAM/CLOCK SET**.

Note:

If there is a power failure, the clock loses the setting and is reset to "0:00." The clock indication will keep flashing until you set the clock again.

To show the clock when CD or tuner is selected

Press **DISPLAY**.

Each time you press the button, the display changes the clock indication and the normal indication alternately. (Operating the unit while clock indication is displayed changes the display to the normal indication.)

DISPLAY



Main unit

DISPLAY



Remote

ADJUSTING THE SOUND

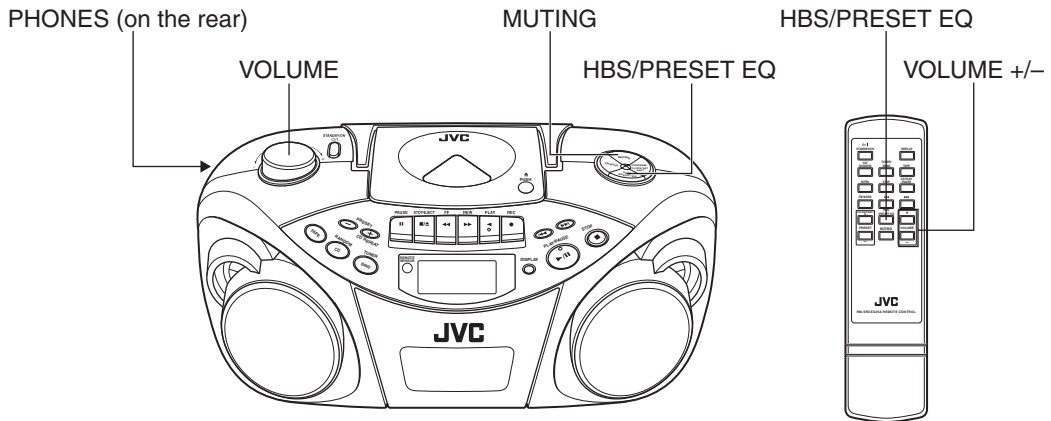

Adjusting the volume

Turn **VOLUME** clockwise to increase the volume or counterclockwise to decrease it.

You can press **VOLUME +** or **VOLUME -** on the remote control unit to increase or decrease the volume respectively.

The volume level can be adjusted in 31 steps (00 VOL to 30 VOL).



Caution:

DO NOT turn off the unit with the volume set to an extremely high level; otherwise a sudden blast of sound could damage your hearing and/or the speakers and headphones, when you turn on the unit or start playing another source next time.

REMEMBER you cannot adjust the volume unless the unit is turned on.

Turning off the sound temporarily

During playback, press **MUTING**.

The sound is turned off and the **MUTING** indicator appears in the display window.

To restore the sound, press **MUTING** again.

Listening through headphones

Connect a pair of headphones to the **PHONES** jack.

No sound comes out of the speakers anymore. Be sure to turn down the volume before connecting headphones.

Reinforcing the bass sound

You can enjoy powerful bass sound with the Hyper-Bass Sound effect.

Press and hold **HBS/PRESET EQ** so that the **HBS** indicator lights up in the display window.

To turn off the effect, press and hold the button again so that the **HBS** indicator goes off.

Selecting the sound mode

You can select one of the 5 preset sound modes.

CLASSIC: Good for classical music.

ROCK : Boosts low and high frequency. Good for acoustic music.

POP : Good for vocal music.

JAZZ : Good for jazz music.

FLAT : Normal sound.

To select the sound mode

Press **HBS/PRESET EQ** repeatedly until the indicator for the sound mode you want appears in the display window.

Each time you press the button, the sound mode changes as follows:

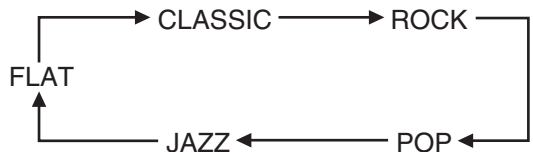

PLAYING COMPACT DISCS

Notes on compact discs

This unit has been designed only to play back the following CDs.

- Digital audio CD
- Recordable digital audio CD (CD-R)
- Rewritable digital audio CD (CD-RW)



When playing a CD-R or CD-RW

You can play back **finalized CD-R or CD-RW** recorded in **music CD format**. (If a CD-RW has been recorded in a different format, erase all the data on the CD-RW completely before recording on it.)

- You can play back CD-R or CD-RW like an audio CD.
- Some CD-R or CD-RW may not be played back on this unit because of their disc characteristics, damage or stain on them, or if the player lens is dirty.
- The reflection factor of CD-RW is lower than that of other CDs, possibly causing CD-RW to take longer time to read.
- CD-R and CD-RW of MP3 format cannot be played back.

Handling discs

Since dirty, damaged or warped discs could damage the unit, care should be taken of the following:

- Do not touch the reflective recorded surface.
- Do not stick or write anything on the label side.
- Do not bend discs.

Storage

- After removing a disc from the unit, be sure to put it back in its case.
- Do not expose discs to direct sunlight, high temperatures from a heater, etc., high humidity or dust.

Cleaning discs

Before loading a disc, wipe off any dust, dirt or fingerprints with a soft, dry cloth. Discs should be cleaned by wiping radially, from the center to edge.

Never use thinner, benzene, record cleaner or antistatic spray.

- Removing the disc from its storage case and replacing it

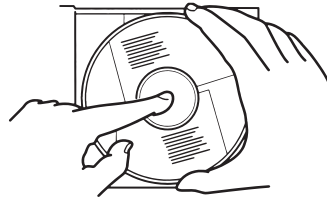

Press the center and lift out.

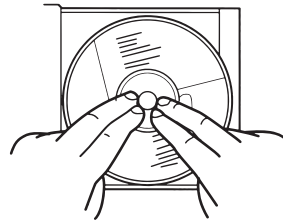

Press to secure the disc.

- Handling

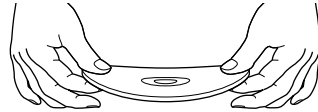

Incorrect

- Cleaning



Correct



Incorrect

Basic operation

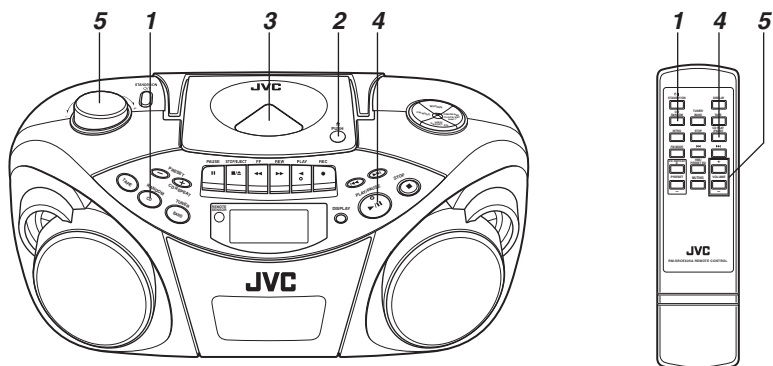

1 Press CD/RANDOM to enter CD mode, if the unit is in TUNER or TAPE mode.

You can press CD/RANDOM on the remote control unit to enter CD mode.

2 Press \triangle PUSH to open the disc door.

3 Load a disc with the label side facing up and close the disc door.

- 8-cm CD can be played on the unit without an adapter.

4 Press PLAY/PAUSE \blacktriangleright /II to start playback.

You can start playback by pressing CD PLAY/PAUSE on the remote control unit.

The current track number and elapsed playing time are displayed during playback.

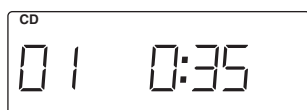

5 Adjust the volume.

Notes:

- The following indication may be displayed when the disc is loaded upside down. Reload the disc correctly.

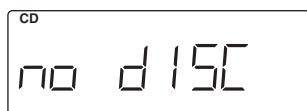

- If mistracking occurs during playback, lower the volume.
- Mistracking may occur if a strong shock is applied to the unit or if it is used in a place subject to vibrations (e.g. in a car travelling on a rough road).
- If you press CD/RANDOM while in CD mode, the unit enters the random playback mode.

To stop playback

Press STOP \blacksquare .

You can press STOP on the remote control unit to stop playback.



Main unit



Remote

Caution:

Stop playback before opening the disc door. Check that the disc has completely stopped rotating before unloading the disc.

To pause playback

Press PLAY/PAUSE \blacktriangleright /II during playback.

You can press CD PLAY/PAUSE on the remote control unit to stop playback.

To resume playback, press the button again.



Main unit

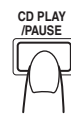

Remote

Skipping

- **To skip back to the previous track**

During playback, press **⏮** once to return to the beginning of the current track, press twice to skip back to the beginning of the previous track.

- **To skip to the next track**

During playback, press **⏭** to skip to the beginning of the next track.

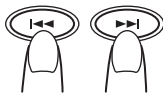

Main unit

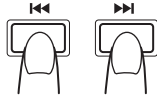

Remote

Search – locating a desired position on the disc

Press and hold **⏮ or **⏭** during playback.**

Monitor the sound and release the button when the desired position is located.

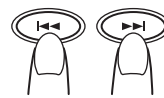

Main unit

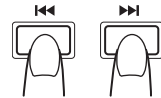

Remote

Repeat/Random playback

CD/RANDOM PRESET+/CD REPEAT

CD REPEAT/PRESET + CD/RANDOM

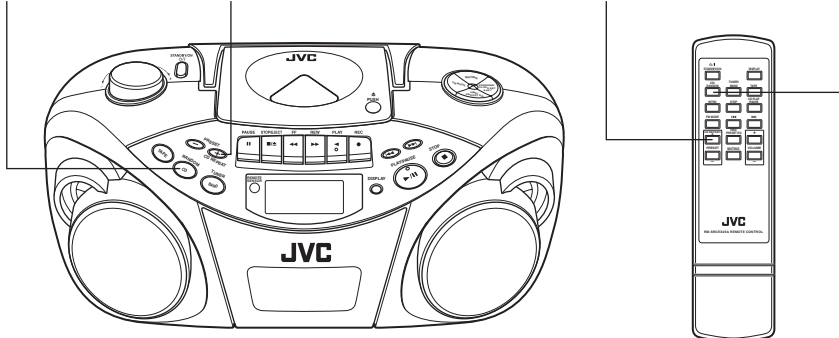

Repeat playback

Press PRESET + / CD REPEAT during playback.

You can press CD REPEAT / PRESET + on the remote control unit to select repeat playback.

Each time you press the button, the repeat mode changes in the following order:

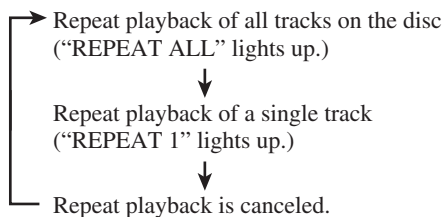

Random playback

Press CD/RANDOM in CD mode so that the RANDOM indicator lights up in the display window.

You can press CD/RANDOM on the remote control unit to select random playback.

Tracks are played in random order.

To cancel random playback, press the button again so that the RANDOM indicator goes off.

Programmed playback

Up to 20 tracks can be programmed to play in any desired order.

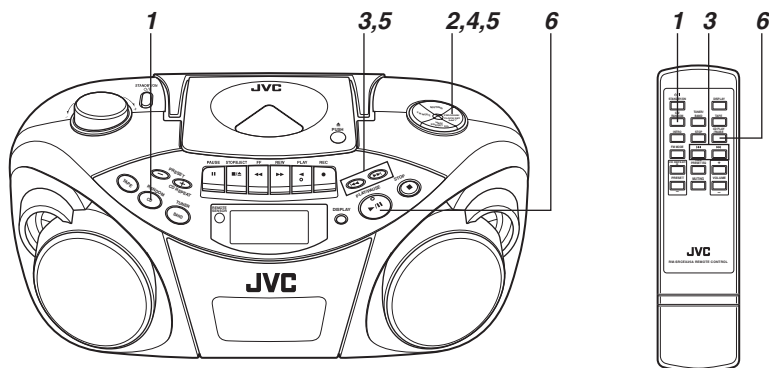

Note:

There is a time limit in doing the following steps. If the setting is canceled before you finish, start from step 2 again.

1 Press CD/RANDOM to enter CD mode.

You can press CD/RANDOM on the remote control unit to enter CD mode.

2 Press PROGRAM/CLOCK SET in stop mode.

The PROG indicator starts blinking in the display window.

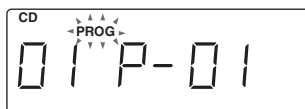

3 Press ◀◀ or ▶▶ to select a desired track to be programmed.

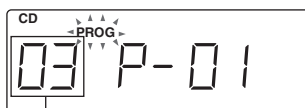

Track to be programmed

4 Press PROGRAM/CLOCK SET.

5 Repeat steps 3 and 4 to program other tracks.

6 Press PLAY/PAUSE ▶/|| while the PROG indicator blinks.

The tracks are played in the order you have programmed.

You can press CD PLAY/PAUSE on the remote control unit to start programmed playback.

Notes:

- If the PROG indicator goes off before you press PLAY/PAUSE ▶/|| (or CD PLAY/PAUSE on the remote control unit), press PROGRAM/CLOCK SET, then start playback.
- If you press CD/RANDOM while in CD mode, the unit enters the random playback mode.

To stop during playback

Press STOP ■ (or STOP on the remote control unit). The PROG indicator goes off and the unit exits from programmed playback.

To check the program contents

Before starting programmed playback, press PROGRAM/CLOCK SET.

Each time you press the button, the programmed tracks are shown in the display window.

To add tracks in the program

1 Press PROGRAM/CLOCK SET repeatedly so that "00" appears as the track number.

2 Press ◀◀ or ▶▶ to select the track number, then press PROGRAM/CLOCK SET.

To edit the program

1 Press PROGRAM/CLOCK SET repeatedly so that the program number you want to edit is shown.

2 Press ◀◀ or ▶▶ to select a new track number, then press PROGRAM/CLOCK SET.

To repeat programmed playback

Press PRESET + / CD REPEAT (or CD REPEAT / PRESET + on the remote control unit) after starting programmed playback.

To erase the entire program in the memory

Press PROGRAM/CLOCK SET so that the PROG indicator blinks, and press STOP ■ (or STOP on the remote control unit) while the PROG indicator blinks.

The stored program is also cleared when the disc door is opened.

Note:

After you have programmed 20 tracks, the program number returns to "1." Programming more tracks overwrite the tracks already programmed to those numbers.

Playing back introductions – Intro playback

Every track or every programmed track of a CD can be played for the beginning ten seconds.

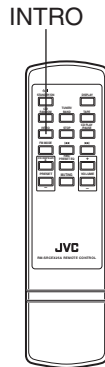

Press INTRO.

The INTRO indicator appears in the display window and intro playback starts.

To use intro playback for programmed and random playback, press the button after starting playback.

Note:

If you press INTRO while playing a track over ten seconds from the beginning, the introduction of the next track begins to play.

To stop during playback

Press STOP ■ (or STOP on the remote control unit).

The INTRO indicator goes off and the unit exits from the intro playback.

To cancel intro playback without stopping

Press INTRO during playback.

The INTRO indicator goes off and the unit continues playback.

RADIO RECEPTION

Tuning in a station

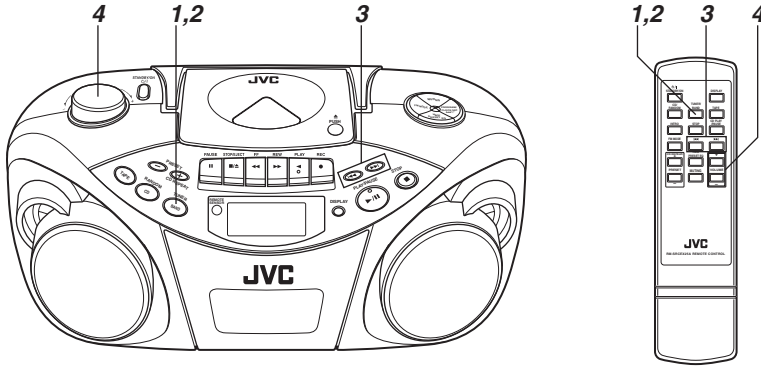

- 1 Press BAND/TUNER to enter the tuner mode.**
- 2 Press BAND/TUNER to select the band, FM or AM.**
- 3 Press and hold ◀◀ or ▶▶ for more than 1 second.**
The unit starts searching and stops when a station of sufficient signal strength is tuned in.
If you press ◀◀ or ▶▶ briefly and repeatedly, the frequency changes step by step.
- 4 Adjust the volume.**

Changing the FM reception mode

When an FM stereo broadcast is hard to receive or noisy, reception improves in monaural reception.

Press FM MODE so that the MONO indicator appears in the display window.

To restore the stereo effect, press FM MODE again so that the MONO indicator goes off.



Main unit



Remote

Note:

The FM reception mode setting will be canceled when you tune in another station.

Using the antennas

FM

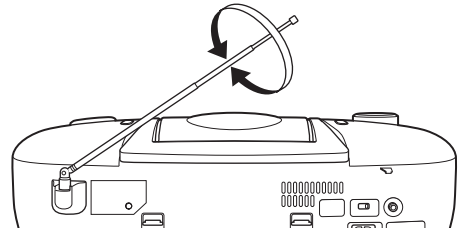

AM

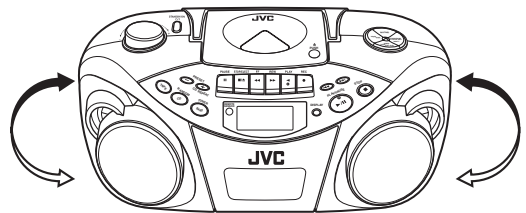

Note:

The built-in ferrite core antenna may pick up interference from television receivers in the neighborhood disturbing AM reception.

Presetting stations

You can preset 10 FM and 10 AM stations.

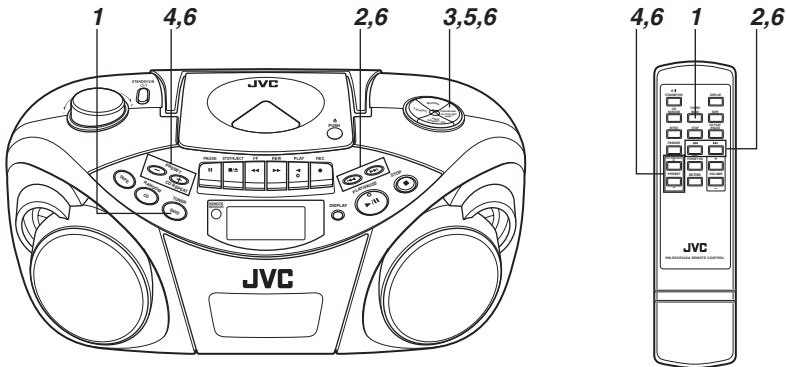

There is a time limit in doing the following steps. If the setting is canceled before you finish, start from step 3 again.

Note:

In some cases, test frequencies have been already memorized for the tuner since the factory examined the tuner preset function before shipment. This is not a malfunction. You can preset the stations you want into memory by following the presetting method.

1 Press BAND/TUNER to select the band, FM or AM.

2 Press |◀◀ or ▶▶| to tune in the station you want to preset.

3 Press PROGRAM/CLOCK SET.

The PROG indicator starts blinking in the display window.

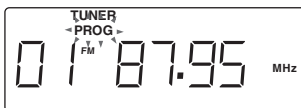

4 Press PRESET + / CD REPEAT or PRESET - to select the preset number.

You can press CD REPEAT / PRESET + or PRESET - on the remote control unit to select the preset number.

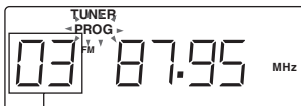

Preset number

5 Press PROGRAM/CLOCK SET.

The tuned station in step 2 is stored in the preset number selected in step 4.

Storing a new station on a used number erases the previously stored one.

6 Repeat steps 2 to 5 to preset other stations, using different preset numbers.

Tuning in a preset station

1 Press BAND/TUNER to select the band, FM or AM.

2 Press PRESET + / CD REPEAT or PRESET - repeatedly until the desired preset number appears.

Note:

If you unplug the AC power cord or if a power failure occurs, the preset stations will be erased in a few days. If this happens, preset the stations again.

CASSETTE PLAYBACK

Notes on cassette tapes

- Use only type-I normal tapes. The recording/playback characteristics of this unit are those for normal tapes, which have different characteristics from CrO₂ and metal tapes.
- The use of tapes longer than 120 minutes is not recommended, since characteristic deterioration may occur and these tapes easily jam in the pinch roller and the capstan.
- Loose tape may cause trouble. Gently tighten the tape with a pencil as shown in the figure below.

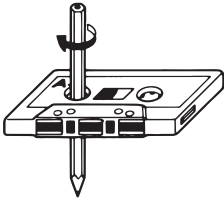

Turn the pencil to take up the slack.

- To prevent recordings from being accidentally erased, remove the tab(s) with a screwdriver. After the tabs have been broken off, reseal the slots with adhesive tape to erase or re-record.



Loading a cassette

- 1 Press STOP/EJECT ■/▲ to open the cassette holder.**
- 2 Load a cassette with the open side up and the playback side facing out as shown in the figure below.**

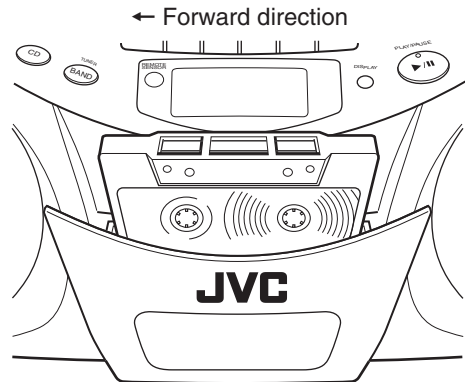

- 3 Close the cassette holder by pressing it gently and firmly.**

The cassette holder clicks back into position.

Basic operation

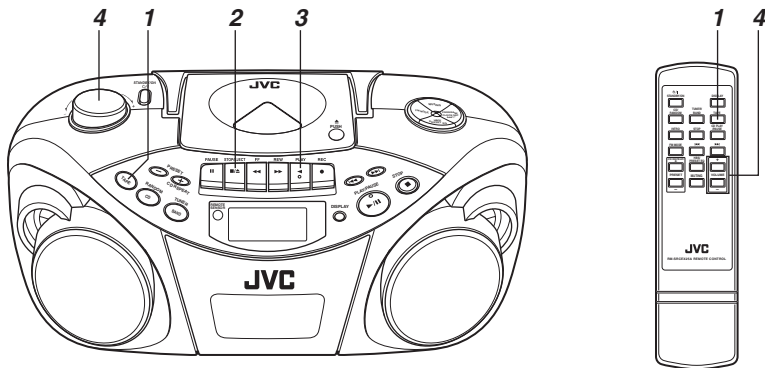

1 Press **TAPE** to enter the tape mode.

2 Load a cassette.

Use only a type-I normal tape.

3 Press **PLAY** ◀ to start playback.

4 Adjust the volume.

Fast-winding a tape

Press **REW** ▶▶ or **FF** ◀◀.

When the tape reaches the end, press **STOP/EJECT** ■/▲ to release **REW** ▶▶ or **FF** ◀◀.

To stop playback

Press **STOP/EJECT** ■/▲.

The tape also stops when it reaches the end.

RECORDING

Basic operation

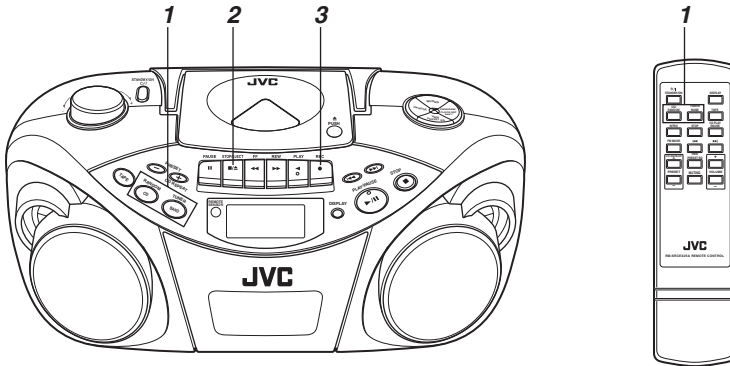

Standard recording

1 Prepare the recording source.

- When recording from the radio:
Set to the tuner mode and tune in a desired station.
- When recording from a CD:
Set to the CD mode and load a CD.

2 Load a blank or erasable cassette.

Use only a type-I normal tape.

3 Press REC ●.

PLAY ◀ is also depressed, and recording starts.

To stop recording

Press STOP/EJECT ■/▲.

The tape also stops when it reaches the end.

Notes:

- **It should be noted that it may be unlawful to re-record pre-recorded tapes, records, or discs without the consent of the owner of copyright in the sound or video recording, broadcast or cable program and in any literary, dramatic, musical, or artistic work embodied therein.**
- The recording level is automatically set correctly, so it is not affected by VOLUME. Thus, during recording you can adjust the sound you are actually listening to without affecting the recording level.
- If a recording you made has excessive noise or static, the unit may have been too close to a TV which was on during the recording. Either turn off the TV or increase the distance between the TV and the unit.

Using the beat-cut function

When recording an AM broadcast, beats may occur. If this happens, change the BEAT CUT switch on the rear of the unit to either "1" or "2" to reduce the beating sound.

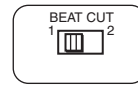

To start recording at the exact moment

- 1 Press PAUSE || first, then press REC ●, thus entering the record-pause (standby) mode.
- 2 Press PAUSE || to release the tape at the exact moment you want to start recording.

Note:

Do not leave the unit in pause mode for more than a few minutes. Instead, press STOP/EJECT ■/▲ to stop the tape.

Synchronized recording with CD playback

You can make the CD player to start playback when the tape deck enters the recording mode.

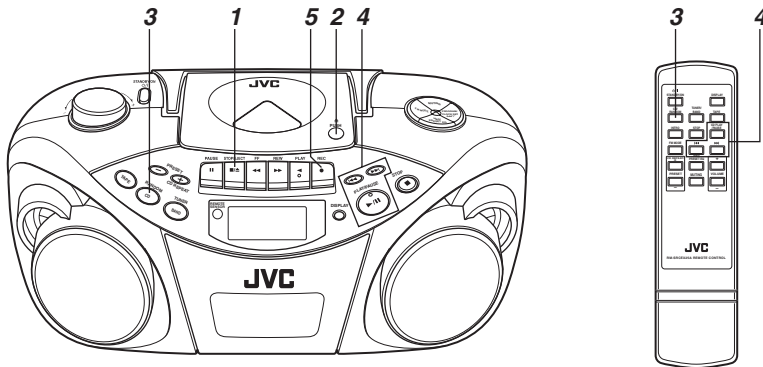

1 Load a cassette.

Use only a type-I normal tape.

2 Load a CD.

3 Press CD/RANDOM to enter CD mode.

You can press CD/RANDOM on the remote control unit to enter CD mode.

4 Specify a track or point on the disc to start recording.

- To start recording from the desired track, select the track by pressing **◀◀** or **▶▶** in stop mode.
- To start recording from the desired point on a disc, play the disc and pause at the desired point by pressing **▶/||** (or CD PLAY/PAUSE on the remote control unit).

5 Press REC ●.

PLAY ◀ is also depressed, and synchronized recording starts.

- The CD SYNC indicator appears in the display window during synchronized recording.

When the tape reaches the end first, the CD player enters the pause mode. Press **▶/||** (or CD PLAY/PAUSE on the remote control unit) to continue playback, or press **■** (or STOP on the remote control unit) to stop playback.

When the CD player stops first, the tape continues running. In this case, press **■/▲** to stop the tape.

Erasing

When recording on a pre-recorded tape, the previous recording is erased and only the new recording is heard next time the tape is played back.

To erase a tape without making a new recording

1 Press TAPE on the unit to enter the tape mode.

2 Press REC ●.

MAINTENANCE

Cleaning the heads, capstan and pinch roller

Cleaning is important!

When the tape is running, magnetic powder and dust naturally accumulate on the heads, capstan and pinch roller. When they become too dirty;

- Sound quality deteriorates.
- The sound output level drops.
- The previous recording is not completely erased.
- Recording is not performed satisfactorily.

To avoid these, clean the heads, capstan and pinch roller every 10 hours of use.

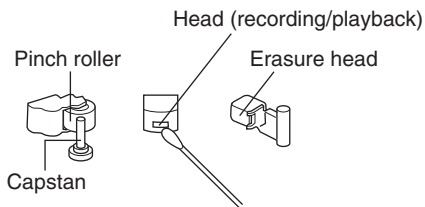

Open the cassette holder. Clean the heads, capstan and pinch roller.

For effective cleaning, use a cleaning kit available at an audio store.

After cleaning, make sure that the cleaning fluid has dried completely before loading a cassette.

Cautions:

- Keep magnets and metallic objects away from the head. If the head becomes magnetized, noise will increase and the sound will deteriorate.
- Demagnetize the recording/playback head every 20 to 30 hours of use with a head demagnetizer available at an audio store. When demagnetizing the head, the unit should be turned off.

As the erasure head of the unit is of magnetic type, do not demagnetize it.

- Do not use anything other than alcohol for cleaning. Thinner and benzine will damage the rubber pinch roller.

Cleaning the CD pickup lens

If the CD pickup lens is dirty, the sound may be degraded.

Open the disc door and clean the lens.

Use a blower (available at a camera store, etc.) to blow off dust on the lens.

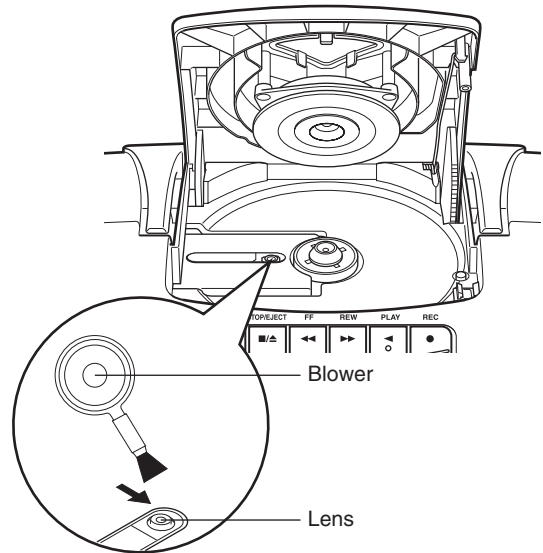

TROUBLESHOOTING

- If you are having a problem with your unit, check this list for a possible solution before calling for service.
- If you cannot solve the problem from the hints given here, or the unit has been physically damaged, call a qualified person, such as your dealer, for service.

Symptom	Possible cause	Action
Power cannot be turned on.	The power cord is unplugged.	Connect the power cord.
When PLAY ◀ is pressed, tape does not move.	PAUSE is pressed.	Press PAUSE again to release it.
Playback sound is at a very low level.	<ul style="list-style-type: none"> • Batteries are run down. • The head is dirty. 	<ul style="list-style-type: none"> • Replace the batteries with new ones. • Clean the head.
REC ● does not function.	<ul style="list-style-type: none"> • The safety tabs of the cassette have been broken off. • No cassette is loaded. 	<ul style="list-style-type: none"> • Reseal the slots with adhesive tape. • Load a cassette.
The disc is loaded but does not play.	<ul style="list-style-type: none"> • The disc is upside down. • The disc is dirty. • The disc is damaged or warped. • The lens is dirty. • There is moisture condensation. 	<ul style="list-style-type: none"> • Load the disc with the label side facing up. • Clean the disc. • Replace the disc with a playable one. • Clean the lens. • Turn the unit on and wait one or two hours before use.
No sound from the speakers.	Headphones are connected.	Disconnect the headphones.
Since the tape speed is irregular, wow and flutter occur.	<ul style="list-style-type: none"> • The pinch roller or capstan is dirty. • Batteries are run down. 	<ul style="list-style-type: none"> • Clean the pinch roller and capstan. • Replace the batteries with new ones.
Radio reception is poor and there is much static.	The antenna is not properly adjusted.	Adjust the antenna correctly.
Remote control is impossible.	<ul style="list-style-type: none"> • Batteries in the remote control unit are run down. • The remote sensor section is exposed to bright light (direct sunlight, etc.) 	<ul style="list-style-type: none"> • Replace the batteries with new ones. • Try not to operate the unit under direct sunlight, etc.

Note:

When the unit is moved from a cold place of around 0°C to a warm place, it may not operate normally, because moisture has formed inside the deck. Normal operation will be restored after waiting one or two hours.

Resetting the unit

If “TROUBLESHOOTING” does not eliminate malfunctioning (failure to operate or display properly, etc.), press the RESET button on the rear of the unit with something having a sharp point, while the unit is turned on.

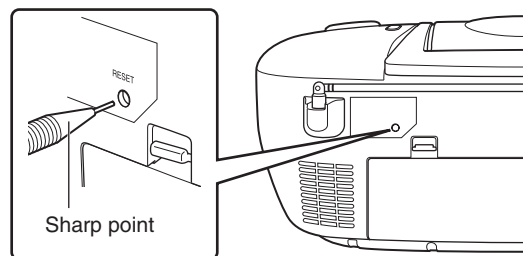

Note:

Resetting causes the unit to restore its factory default settings and results in all the settings made by the user being deleted.

SPECIFICATIONS

CD player

CD capacity	: 1 CD
Signal-to-noise ratio	: 75 dB
Dynamic range	: 60 dB

Tuner

Frequency range	: FM 87.5 – 108.0 MHz AM 522 – 1 629 kHz
Antennas	: Telescopic antenna for FM Ferrite core antenna for AM

Cassette deck

Frequency response	: 60 Hz – 10 000 Hz
Wow & flutter	: 0.15% (WRMS)
Fast wind time	: Approx. 150 sec. (C-60 cassette)

General

Speakers	: 9 cm cone × 2
Speaker impedance	: 4 Ω
Output power	: 4 W (2 W + 2 W) at 4 Ω (10% THD)
Output terminals	: PHONES × 1
Power supply	: AC 230 V \sim , 50 Hz DC 9 V (R20 (SUM-1)/D (13D)-size batteries × 6)
Power consumption	: 13 W (at operation) 3 W (on standby)
Dimensions	: 420 mm × 178 mm × 250 mm (W/H/D)
Mass	: Approx. 3.2 kg (without batteries)
Accessories provided	: AC power cord × 1 Remote control unit × 1 Batteries for the remote control unit (AAA/UM-4/ R03) × 2

Design and specifications are subject to change without notice.



JVC
VICTOR COMPANY OF JAPAN, LIMITED

JVC

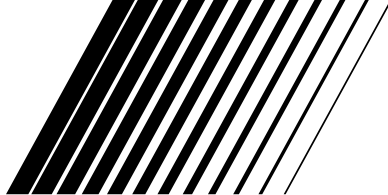

CD PORTABLE SYSTEM

CD-PORTABLE-SYSTEM

CHAINE PORTABLE A CD

DRAAGBAAR CD-SYSTEEM

SISTEMA PORTATIL CON CD

SISTEMA PORTATILE CON LETTORE CD

RC-EX25S

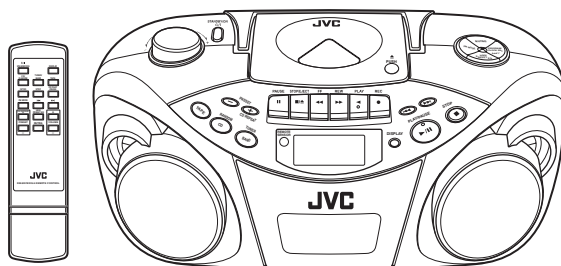

COMPACT
disc
DIGITAL AUDIO



INSTRUCTIONS

BEDIENUNGSANLEITUNG

MANUEL D'INSTRUCTIONS

GEBRUIKSAANWIJZING

MANUAL DE INSTRUCCIONES

ISTRUZIONI

LVT1212-004A
[E]

Warnings, Cautions and Others

Warnung, Achtung und sonstige Hinweise

Mises en garde, précautions et indications diverses

Waarschuwingen, voorzorgen en andere mededelingen

Avisos, Precauciones y Varios

Simboli di avvertenza, attenzione e altri

Caution — STANDBY/ON button!

Disconnect the mains plug to shut the power off completely. The STANDBY/ON button in any position does not disconnect the mains line.

Achtung — STANDBY/ON-Schalter!

Den Netzstecker aus der Steckdose ziehen, um die Stromversorgung vollkommen zu unterbrechen. Der Schalter STANDBY/ON unterbricht in keiner Stellung die Stromversorgung vollkommen.

Attention — Commutateur STANDBY/ON!

Déconnecter la fiche de secteur pour couper complètement le courant. Le commutateur STANDBY/ON ne coupe jamais complètement la ligne de secteur, quelle que soit sa position.

Voorzichtig — STANDBY/ON schakelaar!

Om de stroomtoevoer geheel uit te schakelen, trek u de stekker uit het stopcontact. Anders zal er altijd een geringe hoeveelheid stroom naar het apparaat lopen, ongeacht de stand van de STANDBY/ON schakelaar.

Precaución — Interruptor STANDBY/ON!

Desconectar el cable de alimentación para desactivar la alimentación totalmente. Cualquiera que sea la posición de ajuste del interruptor STANDBY/ON, la alimentación no es cortada completamente.

Attenzione — L'interruttore STANDBY/ON!

Disinserire la spina del cavo di alimentazione dalla presa della rete elettrica per staccare completamente l'alimentazione. L'interruttore STANDBY/ON in nessuna posizione stacca la linea di alimentazione elettrica principale.

Per l'Italia:

“Si dichiara che il questo prodotto di marca JVC è conforme alle prescrizioni del Decreto Ministeriale n.548 del 28/08/95 pubblicato sulla Gazzetta Ufficiale della Repubblica Italiana n.301 del 28/12/95.”

CAUTION

To reduce the risk of electrical shocks, fire, etc.:

1. Do not remove screws, covers or cabinet.
2. Do not expose this appliance to rain or moisture.

ACHTUNG

Zur Verhinderung von elektrischen Schlägen, Brandgefahr, usw:

1. Keine Schrauben lösen oder Abdeckungen enternen und nicht das Gehäuse öffnen.
2. Dieses Gerät weder Regen noch Feuchtigkeit aussetzen.

ATTENTION

Afin d'éviter tout risque d'électrocution, d'incendie, etc.:

1. Ne pas enlever les vis ni les panneaux et ne pas ouvrir le coffret de l'appareil.
2. Ne pas exposer l'appareil à la pluie ni à l'humidité.

VOORZICHTIG

Ter vermindering van gevaar voor brand, elektrische schokken, enz.:

1. Verwijder geen schroeven, panelen of de behuizing.
2. Stel dit toestel niet bloot aan regen of vocht.

PRECAUCIÓN

Para reducir riesgos de choques eléctricos, incendio, etc.:

1. No extraiga los tornillos, las cubiertas ni la caja.
2. No esponga este aparato a la lluvia o a la humedad.

ATTENZIONE

Per ridurre il rischio di shock elettrici, incendi, ecc.:

1. Non toglieate viti, coperchi o la scatola.
2. Non esponete l'apparecchio alla pioggia e all'umidità.

CAUTION

- Do not block the ventilation openings or holes.
(If the ventilation openings or holes are blocked by a newspaper or cloth, etc., the heat may not be able to get out.)
- Do not place any naked flame sources, such as lighted candles, on the apparatus.
- When discarding batteries, environmental problems must be considered and local rules or laws governing the disposal of these batteries must be followed strictly.
- Do not expose this apparatus to rain, moisture, dripping or splashing and that no objects filled with liquids, such as vases, shall be placed on the apparatus.

ACHTUNG

- Blockieren Sie keine Belüftungsschlitze oder -bohrungen.
(Wenn die Belüftungsöffnungen oder -löcher durch eine Zeitung oder ein Tuch etc. blockiert werden, kann die entstehende Hitze nicht abgeführt werden.)
- Stellen Sie keine offenen Flammen, beispielsweise angezündete Kerzen, auf das Gerät.
- Wenn Sie Batterien entsorgen, denken Sie an den Umweltschutz. Batterien müssen entsprechend den geltenden örtlichen Vorschriften oder Gesetzen entsorgt werden.
- Setzen Sie dieses Gerät auf keinen Fall Regen, Feuchtigkeit oder Flüssigkeitsspritzern aus. Es dürfen auch keine mit Flüssigkeit gefüllten Objekte, z. B. Vasen, auf das Gerät gestellt werden.

ATTENTION

- Ne bloquez pas les orifices ou les trous de ventilation.
(Si les orifices ou les trous de ventilation sont bloqués par un journal un tissu, etc., la chaleur peut ne pas être évacuée correctement de l'appareil.)
- Ne placez aucune source de flamme nue, telle qu'une bougie, sur l'appareil.
- Lors de la mise au rebut des piles, veuillez prendre en considération les problèmes de l'environnement et suivre strictement les règles et les lois locales sur la mise au rebut des piles.
- N'exposez pas cet appareil à la pluie, à l'humidité, à un égouttement ou à des éclaboussures et ne placez pas des objets remplis de liquide, tels qu'un vase, sur l'appareil.

VOORZICHTIG

- Zorg dat u de ventilatieopeningen en -gaten niet afsluit.
(Als de ventilatieopeningen en -gaten worden afgesloten door bijvoorbeeld papier of een doek, kan er hitte in het apparaat worden opgebouwd.)
- Zet geen bronnen met open vuur, zoals brandende kaarsen, op het apparaat.
- Wees milieubewust en gooi lege batterijen niet bij het huishoudelijk afval. Lege batterijen dient u in te leveren met het KCA of bij een innamepunt voor batterijen.
- Stel dit apparaat niet bloot aan regen, vocht, drupwater of spatwater en plaats geen enkel voorwerp waarin zich een vloeistof bevindt, zoals een vaas, op het apparaat.

PRECAUCIÓN

- No obstruya las rendijas o los orificios de ventilación.
(Si las rendijas o los orificios de ventilación quedan tapados con un periódico, un trozo de tela, etc., no se podrá disipar el calor.)
- No ponga sobre el aparato ninguna llama al descubierto, como velas encendidas.
- Cuando tenga que descartar las pilas, tenga en cuenta los problemas ambientales y observe estrictamente los reglamentos o las leyes locales sobre disposición de las pilas.
- No exponga este aparato a la lluvia, humedad, goteos o salpicaduras. Tampoco ponga recipientes conteniendo líquidos, como floreros, encima del aparato.

ATTENZIONE

- Evitare di ostruire le aperture o i fori di ventilazione con giornali, indumenti etc., in quanto s'impedirebbe al calore di fuoriuscire.
- Non collocare fiamme libere (es. candele accese) sull'apparecchio.
- Le batterie devono essere smaltite nel rispetto dell'ambiente, attenendosi ai regolamenti locali in materia.
- Non esporre l'apparecchio a pioggia, umidità, gocciolamenti e spruzzi d'acqua ed evitare di sovrapporvi oggetti contenenti liquidi (vasi etc.).

IMPORTANT FOR LASER PRODUCTS

1. CLASS 1 LASER PRODUCT
2. **CAUTION:** Do not open the top cover. There are no user serviceable parts inside the unit; leave all servicing to qualified service personnel.
3. **CAUTION:** Visible and invisible laser radiation when open and interlock failed or defeated. Avoid direct exposure to beam.
4. **REPRODUCTION OF LABEL:** CAUTION LABEL, PLACED INSIDE THE UNIT.

WICHTIG FÜR LASER-PRODUKTE

1. LASER-PRODUKT DER KLASSE 1
2. **ACHTUNG:** Die obere Abdeckung nicht öffnen. Das Gerät enthält keine Teile, die vom Benutzer gewartet werden können. Wartungen nur von qualifiziertem Fachpersonal durchführen lassen.
3. **ACHTUNG:** Sichtbare und unsichtbare Laserstrahlung bei offenem Gerät und Defekt oder Umgehen der Verriegelung. Setzen Sie sich dem Strahl nicht direkt aus.
4. **ANBRINGEN DES ETIKETTS:** WARNHINWEIS-ETIKETT, INNEN AM GERÄT ANGEBRACHT.

IMPORTANT POUR PRODUITS LASER

1. PRODUIT LASER CLASSE 1
2. **ATTENTION:** N'ouvrez pas le couvercle supérieur. Il n'y a aucune pièce réparable par l'utilisateur à l'intérieur de l'appareil; confiez toute réparation à un personnel qualifié.
3. **ATTENTION:** Risque de radiations laser visible and invisible quand l'appareil est ouvert et que le système de verrouillage ne fonctionne pas ou a été mis hors service. Évitez toute exposition directe au rayon.
4. **REPRODUCTION DE L'ÉTIQUETTE:** ÉTIQUETTE DE PRÉCAUTION PLACÉE À L'INTÉRIEUR DE L'APPAREIL.

BELANGRIJK VOOR LASERPRODUKTEN

1. KLASSE 1 LASERPRODUKT
2. **VOORZICHTIG:** Open de bovenste afdekking niet. Er zijn geen door de gebruiker te repareren onderdelen in het toestel; laat onderhoud en reparatie over aan erkend onderhoudspersoneel.
3. **VOORZICHTIG:** Zichtbare en onzichtbare laserstraling indien open en interlock defect of buiten werking gesteld. Voorkom directe blootstelling aan de straal.
4. **REPRODUCTIE VAN LABEL:** WAARSCHUWINGSLABEL IN TOESTEL AANGEBRACHT.

IMPORTANTE PARA PRODUCTOS LÁSER

1. PRODUCTO LÁSER CLASE 1
2. **PRECAUCIÓN:** No abra la tapa superior. En el interior de la unidad no hay piezas que pueda reparar el usuario; encargue el servicio a personal técnico cualificado.
3. **PRECAUCIÓN:** Radiación láser visible e invisible en caso de apertura o con interbloqueo averiado o defectuoso. Evite la exposición directa a los haces.
4. **REPRODUCCIÓN DE LA ETIQUETA:** ETIQUETA DE PRECAUCIÓN, COLOCADA EN EL INTERIOR DE LA UNIDAD.

AVVERTENZE IMPORTANTI SUI PRODOTTI LASER

1. PRODOTTO LASER DI CLASSE 1
2. **ATTENZIONE:** Non aprire il coperchio superiore. Nessuna parte interna dell'unità richiede manutenzione da parte dell'utente; per la manutenzione rivolgersi al personale qualificato.
3. **ATTENZIONE:** Quando l'unità è aperta e il dispositivo di sincronizzazione è guasto o non funzionante, si può verificare l'emissione di radiazioni laser visibili o non visibili. Evitare l'esposizione diretta ai raggi laser.
4. **RIPRODUZIONE DELL'ETICHETTA:** ETICHETTA DI AVVERTENZA, POSIZIONATA SULLA SUPERFICIE INTERNA DELL'UNITÀ.

CAUTION - INVISIBLE LASER RADIATION WHEN OPEN AND INTERLOCKS DEFEATED. AVOID EXPOSURE TO BEAM.

VORSICHT ! UNSICHTBARE LASERSTRALUNG TRITT AUS, WENN DECKEL GEÖFFNET UND WENN SICHERHEITSVERRIEGELUNG ÜBERBRÜCKT IST. NICHT DEM STRAHL AUSSETZEN!

VARNING - OSYNLIG LASERSTRÅLNING NÄR DENNA DEL ÄR ÖPPNAD OCH SPÄRR ÄR URKOPPLAD STRÅLEN ÄR FARLIG.

ADVARSEL - USYNLIG LASERSTRÅLING VED ÅBNING NÅR SIKKERHEDSAFBRYDERE ER UDE AF FUNKTION. UDGÅ UDSÆTTELSE FOR STRÅLING.

CONTENTS

FEATURES	1	ADJUSTING THE SOUND	8
SAFETY PRECAUTIONS	1	PLAYING COMPACT DISCS	9
HANDLING PRECAUTIONS	2	RADIO RECEPTION	14
POWER SUPPLY	3	CASSETTE PLAYBACK	16
NAMES OF PARTS AND CONTROLS	4	RECORDING	18
REMOTE CONTROL UNIT	5	MAINTENANCE	20
TURNING THE UNIT ON/OFF	6	TROUBLESHOOTING	21
SETTING THE CLOCK	7	SPECIFICATIONS	22

FEATURES

- 1 **Portable system incorporating CD player**
 - CD functions can be operated with the remote control unit as well as on the main unit.
 - 8-cm CD playback capability
- 2 **Digital LCD (Liquid Crystal Display) indicates general playback status.**
- 3 **Synchronized recording with CD playback**
- 4 **Hyper-Bass Sound effect**

SAFETY PRECAUTIONS

Prevention of Electric Shocks, Fire Hazards and Damages

- Even when the STANDBY/ON button is set to STANDBY, a very small current will flow. When the unit is turned on, the display window lights in orange. When the unit is in standby mode, the display window turns off. (Note, however, that the display window does not light even when the unit is turned on if the unit is operated on batteries.) To save power and for safety when not using the unit for an extended period of time, disconnect the power cord from the household AC outlet.
- Do not handle the power cord with wet hands.
- When unplugging from the wall outlet, always grasp and pull the plug, not the power cord.
- Consult your nearest dealer when damage, disconnection, or contact failure is found with the cord.
- Do not bend the cord sharply, or pull or twist it.
- Rating label is placed on the exterior of the bottom.
- Do not modify the power cord in any manner.
- Do not remove screws to disassemble the unit and do not touch anything inside the unit to avoid accidents.
- Do not insert any metallic objects into the unit.
- Unplug the power cord when there is a possibility of lightning.
- If water gets inside the unit, unplug the power cord from the outlet and consult your dealer.
- Do not block the ventilation holes of the unit so that heat can escape.
- Do not install the unit in a badly ventilated place.

HANDLING PRECAUTIONS

Do not use this unit in direct sunlight or leave the unit in a closed automobile (or yacht, etc.) where it would be exposed to high temperatures above 40°C.

1 Avoid using the unit in the following places:

- Where the temperature may become excessively high or low; the recommended temperature range is 5°C and 35°C.
- Where it could be subject to vibrations.
- Where it is excessively humid, such as in a bathroom.
- Where it could be magnetized by a magnet or speaker.

2 Pay attention to dust.

Be sure to close the disc door so that the lens is not contaminated by dust. Do not touch the lens.

3 Condensation

Condensation may occur in the following cases, in which the unit may not operate correctly:

- The unit is in a room where a heater has just been switched on.
- The unit is in a place where there is smoke or high humidity.
- The unit has just moved from a cold place to a warm room.

In these cases, set the STANDBY/ON button to ON and wait one or two hours before use.

4 Volume control

Compact discs produce very little noise compared with analog records. If you adjust the volume by listening to the noise as you do with analog records, the speakers could be damaged by a sudden blast of sound when playback starts. Therefore, turn down the volume before starting and adjust it as required while playing a CD.

5 Safety mechanism

The unit incorporates a safety interlock mechanism which switches off the laser beam when the disc door is opened.

6 Do not place magnetic objects such as cassette tapes near the speakers.

Since the speakers contain magnets inside, do not place cassette tapes or magnetic cards nearby as recorded data could be erased.

7 Keep the unit away from the TV.

When the unit is used near a TV, the TV picture could be distorted. If this happens, move the unit away from the TV. If this does not correct the situation, avoid using the unit when the TV is turned on.

8 Cleaning the cabinet

If the cabinet gets dirty, wipe it with a soft, dry cloth. Never use benzine or thinner as these could damage the surface finish.

9 When listening with headphones

- Do not listen at high volumes as it could damage your hearing.
- For safety, do not drive while listening with headphones.

10 Carrying handle

Do not raise or lower the carrying handle with the telescopic antenna extended, to avoid damaging the antenna. Position the carrying handle so that it does not interfere with operation.

POWER SUPPLY

Operation on household AC

Connect the AC power cord.

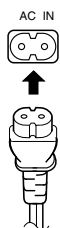

CAUTIONS:

- Use only with the JVC power cord provided with this unit to avoid malfunction or damage to the unit. Remove batteries when using the power cord.
- Be sure to unplug the power cord from the outlet when going out or when the unit is not in use for an extended period of time.

Operation on batteries

Loading batteries

1 Open the battery cover.

Pull the battery cover toward you while pressing the sections marked by the arrows.

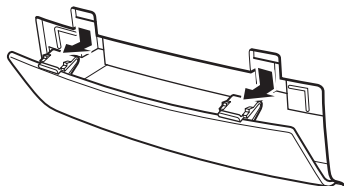

2 Insert six R20 (SUM-1)/D (13D)-size batteries.

Be sure to insert the batteries with the \oplus and \ominus terminals positioned correctly.

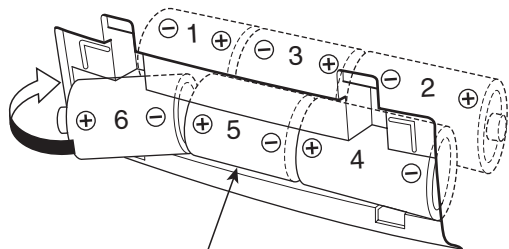

R20 (SUM-1)/D (13D)-size batteries

3 Replace the cover.

Checking batteries

When the tape speed or output sound level decreases, or CD playback becomes intermittent, replace all batteries with fresh ones.

When making an important recording, use new batteries (preferably alkaline batteries for a longer service life) to avoid any possible failure.

For better battery usage

- Continuous operation of the unit causes the battery power to be consumed more quickly than noncontinuous operation.
- Operation of the unit in a cold place causes the battery power to be consumed more quickly than in a warm place.

CAUTIONS:

- When not using the unit for a long time (more than two weeks) or when using the household AC, remove the batteries to avoid a malfunction or damage to the unit.
- When the JVC power cord provided with this unit is connected, the power is automatically switched from the batteries to the household AC even when the batteries are loaded.

However, remove the batteries when using the power cord.

CAUTIONS WHEN USING BATTERIES:

When batteries are used incorrectly, it may result in the leakage of chemicals from the batteries or they may explode. The following care should be taken:

- Check that the positive \oplus and negative \ominus terminals of the batteries are positioned correctly and load them as shown in the figure on the left.
- Do not mix new and old batteries together, or mix different types of batteries.
- Do not try to recharge non-rechargeable batteries.
- Remove the batteries when the unit is not to be used for an extended period of time.

If chemicals from the batteries come in contact with your skin, wash them off immediately with water. If chemicals leak onto the unit, clean the unit completely.

NAMES OF PARTS AND CONTROLS

Top and front sides

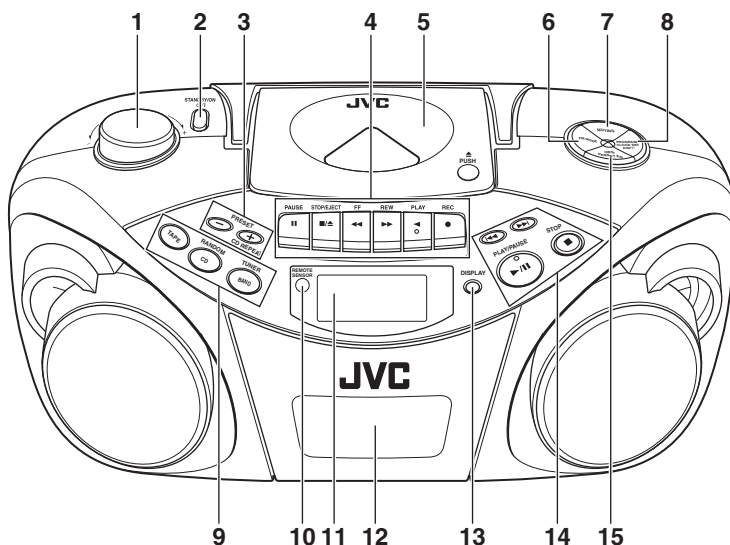

- | | |
|---|--|
| <p>1 VOLUME knob</p> <p>2 STANDBY/ON O/I button</p> <p>3 PRESET – button
PRESET + / CD REPEAT button</p> <p>4 Tape operation buttons
PAUSE II button
STOP/EJECT $\blacksquare/\blacktriangle$ button
FF \lll button
REW \ggg button
PLAY \blacktriangleleft button
REC \bullet button</p> <p>5 Disc door</p> <p>6 FM MODE button</p> <p>7 MUTING button</p> | <p>8 PROGRAM/CLOCK SET button</p> <p>9 TAPE button
CD/RANDOM button
BAND/TUNER button</p> <p>10 REMOTE SENSOR</p> <p>11 Display window</p> <p>12 Cassette deck</p> <p>13 DISPLAY button</p> <p>14 \lll button
\ggg button
PLAY/PAUSE $\blacktriangleleft/\text{II}$ button
STOP \blacksquare button</p> <p>15 HBS/PRESET EQ button</p> |
|---|--|

Rear side

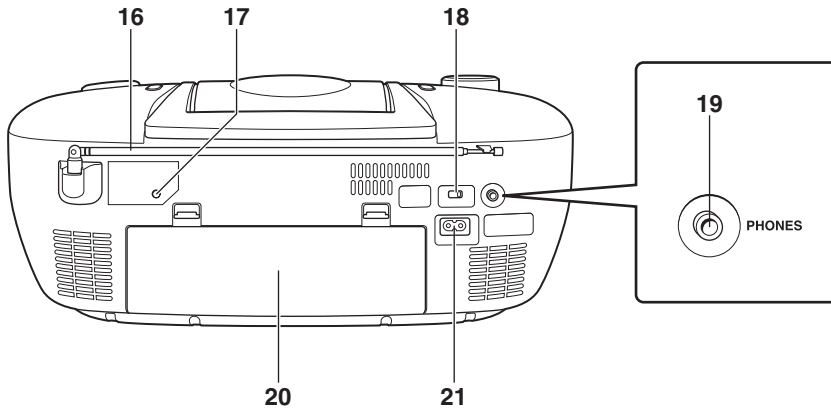

16 Telescopic antenna

17 RESET button

18 BEAT CUT switch

19 PHONES jack

Connect stereo mini headphones (3.5-mm diameters, impedance of 16 Ω to 32 Ω) to this jack. The speaker output is switched off with headphones connected.

20 Battery compartment cover

21 \sim AC IN (AC input) jack

REMOTE CONTROL UNIT

Installing batteries

1 Remove the battery cover from the back of the remote control unit.

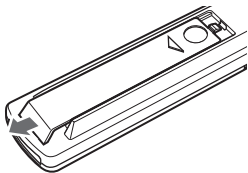

2 Insert two AAA (UM-4)/R03-size batteries (supplied).

Insert the batteries with the \oplus and \ominus terminals matching the indication inside the battery compartment. Insert the \ominus ends first.

AAA (UM-4)/R03-size batteries

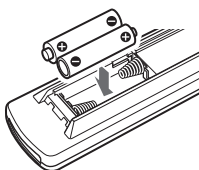

3 Replace the battery cover.

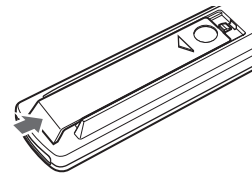

Battery replacement

The maximum operating distance between the remote control unit and the remote sensor section of the unit is approximately 7 meters. When the operating range decreases or remote control operation becomes unstable, replace the batteries with new ones.

Notes on using the remote control unit

- Point the top of the remote control unit toward the remote sensor section of the unit as directly as possible. The operable distance from the main unit decreases if you point the remote control unit at an angle.
- Press the buttons gently and firmly.
- Do not expose the remote sensor section of the unit to strong light (direct sunlight or artificial lighting) and make sure that there are no obstacles between the remote sensor section and the remote control unit.

Names of buttons

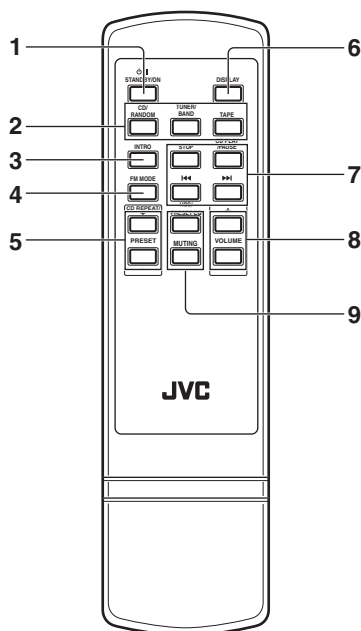

- 1 STANDBY/ON button
- 2 CD/RANDOM button
TUNER/BAND button
TAPE button
- 3 INTRO button
- 4 FM MODE button
- 5 CD REPEAT / PRESET + button
PRESET - button
- 6 DISPLAY button
- 7 STOP button
CD PLAY/PAUSE button
 button
 button
- 8 VOLUME + button
VOLUME - button
- 9 HBS/PRESET EQ button
MUTING button

TURNING THE UNIT ON/OFF

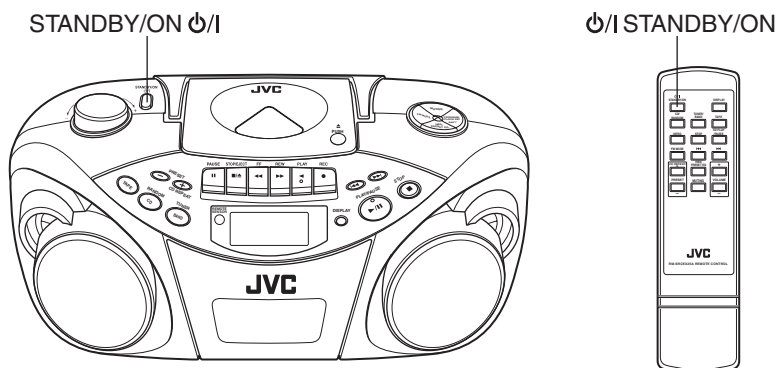

STANDBY/ON



STANDBY/ON button

Press the STANDBY/ON button on the unit to turn on and off the unit.

You can also press the STANDBY/ON button on the remote control unit.

The display window lights up when the unit is turned on. (Note, however, that the display window does not light even when the unit is turned on if the unit is operated on batteries.) The unit comes on ready to play the source selected when the unit was last turned off.

To switch off the power supply completely

Unplug the AC power cord from the AC outlet. If the batteries are inserted in the unit, take them out.

Notes:

- When you unplug the AC power cord or if a power failure occurs, the clock is reset to "0:00" right away, while the tuner preset stations (see page 15) will be erased in a few days. The clock indication will keep flashing until you set the clock again.
- Remove the batteries when carrying the unit by hand or in the trunk of a car. This prevents the power from being accidentally turned on, thus avoiding wasteful battery consumption.

SETTING THE CLOCK

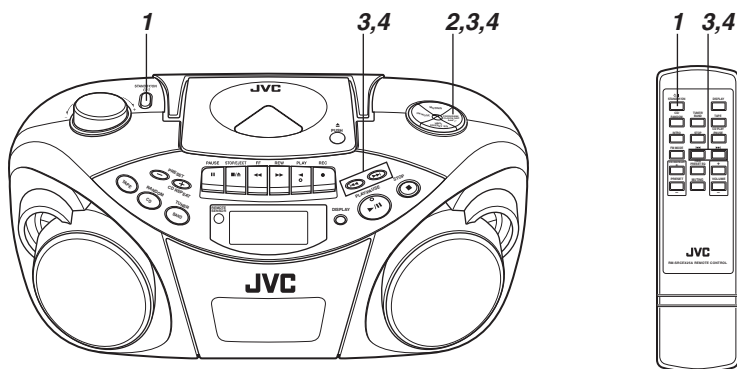

Before operating the unit any further, first set the clock built in this unit.

The clock uses 24-hour indication.

1 Press **STANDBY/ON** to turn off the unit, if it is turned on.

The clock flashes on the display window.

2 Press and hold **PROGRAM/CLOCK SET** for more than 2 seconds.

The hour digits start flashing.



3 Press **◀◀** or **▶▶** to adjust the hour, then press **PROGRAM/CLOCK SET**.

The minute digits start flashing.



4 Press **◀◀** or **▶▶** to adjust the minutes, then press **PROGRAM/CLOCK SET**.

Note:

If there is a power failure, the clock loses the setting and is reset to "0:00." The clock indication will keep flashing until you set the clock again.

To show the clock when CD or tuner is selected

Press **DISPLAY**.

Each time you press the button, the display changes the clock indication and the normal indication alternately. (Operating the unit while clock indication is displayed changes the display to the normal indication.)



Main unit



Remote

ADJUSTING THE SOUND

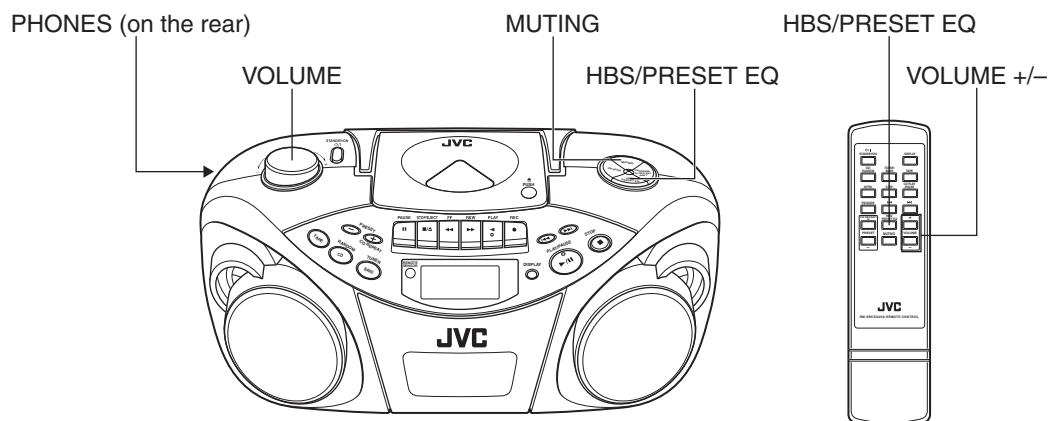

Adjusting the volume

Turn **VOLUME** clockwise to increase the volume or counterclockwise to decrease it.

You can press **VOLUME +** or **VOLUME -** on the remote control unit to increase or decrease the volume respectively.

The volume level can be adjusted in 31 steps (00 VOL to 30 VOL).



Caution:

DO NOT turn off the unit with the volume set to an extremely high level; otherwise a sudden blast of sound could damage your hearing and/or the speakers and headphones, when you turn on the unit or start playing another source next time.

REMEMBER you cannot adjust the volume unless the unit is turned on.

Turning off the sound temporarily

During playback, press **MUTING**.

The sound is turned off and the **MUTING** indicator appears in the display window.

To restore the sound, press **MUTING** again.

Listening through headphones

Connect a pair of headphones to the **PHONES** jack.

No sound comes out of the speakers anymore. Be sure to turn down the volume before connecting headphones.

Reinforcing the bass sound

You can enjoy powerful bass sound with the Hyper-Bass Sound effect.

Press and hold **HBS/PRESET EQ** so that the **HBS** indicator lights up in the display window.

To turn off the effect, press and hold the button again so that the **HBS** indicator goes off.

Selecting the sound mode

You can select one of the 5 preset sound modes.

CLASSIC: Good for classical music.

ROCK : Boosts low and high frequency. Good for acoustic music.

POP : Good for vocal music.

JAZZ : Good for jazz music.

FLAT : Normal sound.

To select the sound mode

Press **HBS/PRESET EQ** repeatedly until the indicator for the sound mode you want appears in the display window.

Each time you press the button, the sound mode changes as follows:



PLAYING COMPACT DISCS

Notes on compact discs

This unit has been designed only to play back the following CDs.

- Digital audio CD
- Recordable digital audio CD (CD-R)
- Rewritable digital audio CD (CD-RW)



When playing a CD-R or CD-RW

You can play back **finalized CD-R or CD-RW** recorded in **music CD format**. (If a CD-RW has been recorded in a different format, erase all the data on the CD-RW completely before recording on it.)

- You can play back CD-R or CD-RW like an audio CD.
- Some CD-R or CD-RW may not be played back on this unit because of their disc characteristics, damage or stain on them, or if the player lens is dirty.
- The reflection factor of CD-RW is lower than that of other CDs, possibly causing CD-RW to take longer time to read.
- CD-R and CD-RW of MP3 format cannot be played back.

Handling discs

Since dirty, damaged or warped discs could damage the unit, care should be taken of the following:

- Do not touch the reflective recorded surface.
- Do not stick or write anything on the label side.
- Do not bend discs.

Storage

- After removing a disc from the unit, be sure to put it back in its case.
- Do not expose discs to direct sunlight, high temperatures from a heater, etc., high humidity or dust.

Cleaning discs

Before loading a disc, wipe off any dust, dirt or fingerprints with a soft, dry cloth. Discs should be cleaned by wiping radially, from the center to edge.

Never use thinner, benzene, record cleaner or antistatic spray.

- Removing the disc from its storage case and replacing it

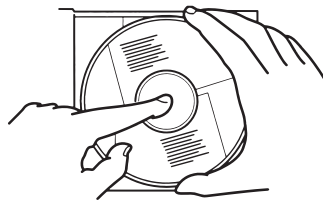

Press the center and lift out.

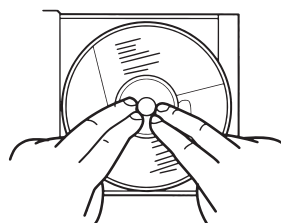

Press to secure the disc.

- Handling

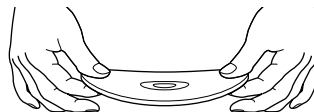

Incorrect

- Cleaning



Correct



Incorrect

Basic operation

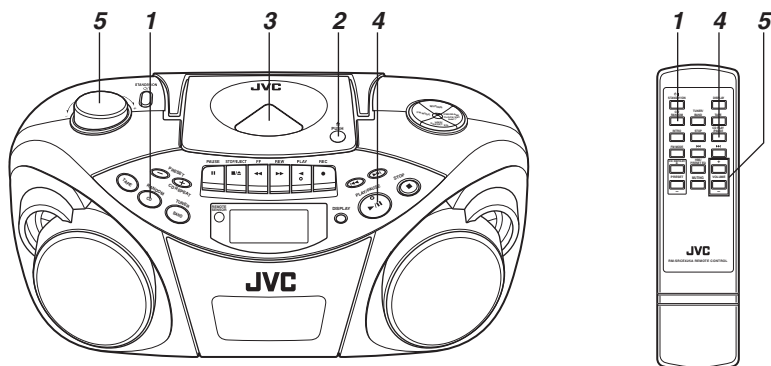

1 Press CD/RANDOM to enter CD mode, if the unit is in TUNER or TAPE mode.

You can press CD/RANDOM on the remote control unit to enter CD mode.

2 Press \triangle PUSH to open the disc door.

3 Load a disc with the label side facing up and close the disc door.

- 8-cm CD can be played on the unit without an adapter.

4 Press PLAY/PAUSE \blacktriangleright /II to start playback.

You can start playback by pressing CD PLAY/PAUSE on the remote control unit.

The current track number and elapsed playing time are displayed during playback.



5 Adjust the volume.

Notes:

- The following indication may be displayed when the disc is loaded upside down. Reload the disc correctly.

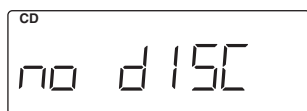

- If mistracking occurs during playback, lower the volume.
- Mistracking may occur if a strong shock is applied to the unit or if it is used in a place subject to vibrations (e.g. in a car travelling on a rough road).
- If you press CD/RANDOM while in CD mode, the unit enters the random playback mode.

To stop playback

Press STOP \blacksquare .

You can press STOP on the remote control unit to stop playback.



Main unit



Remote

Caution:

Stop playback before opening the disc door. Check that the disc has completely stopped rotating before unloading the disc.

To pause playback

Press PLAY/PAUSE \blacktriangleright /II during playback.

You can press CD PLAY/PAUSE on the remote control unit to pause playback.

To resume playback, press the button again.



Main unit

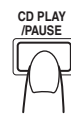

Remote

Skipping

- **To skip back to the previous track**

During playback, press **⏮** once to return to the beginning of the current track, press twice to skip back to the beginning of the previous track.

- **To skip to the next track**

During playback, press **⏭** to skip to the beginning of the next track.

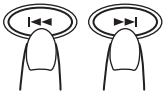

Main unit

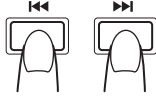

Remote

Search – locating a desired position on the disc

Press and hold **⏮ or **⏭** during playback.**

Monitor the sound and release the button when the desired position is located.

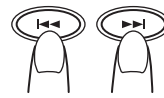

Main unit

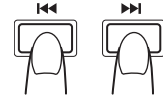

Remote

Repeat/Random playback

CD/RANDOM PRESET+/CD REPEAT

CD REPEAT/PRESET + CD/RANDOM

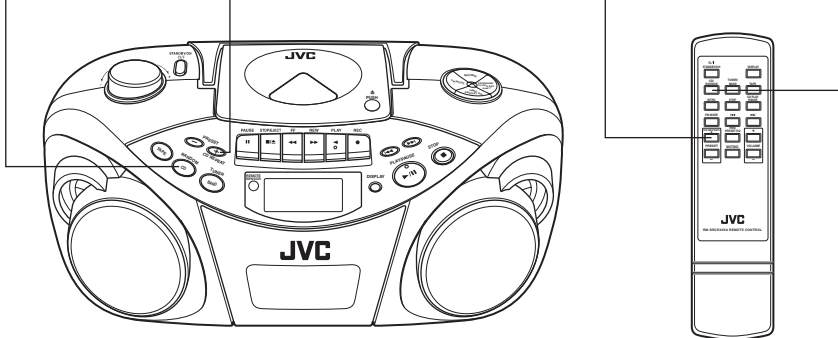

Repeat playback

Press **PRESET + / CD REPEAT** during playback.

You can press **CD REPEAT / PRESET +** on the remote control unit to select repeat playback.

Each time you press the button, the repeat mode changes in the following order:

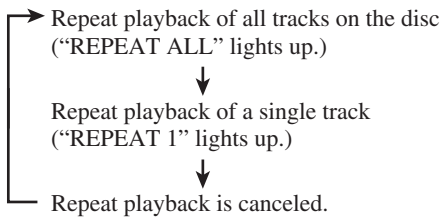

Random playback

Press **CD/RANDOM** in **CD mode** so that the **RANDOM indicator lights up in the display window.**

You can press **CD/RANDOM** on the remote control unit to select random playback.

Tracks are played in random order.

To cancel random playback, press the button again so that the **RANDOM indicator goes off.**

Programmed playback

Up to 20 tracks can be programmed to play in any desired order.

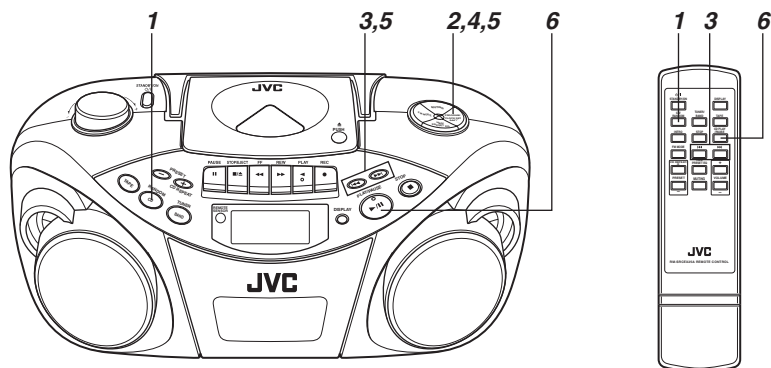

Note:

There is a time limit in doing the following steps. If the setting is canceled before you finish, start from step 2 again.

1 Press CD/RANDOM to enter CD mode.

You can press CD/RANDOM on the remote control unit to enter CD mode.

2 Press PROGRAM/CLOCK SET in stop mode.

The PROG indicator starts blinking in the display window.

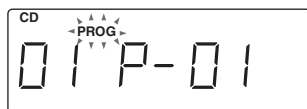

3 Press ◀◀ or ▶▶ to select a desired track to be programmed.

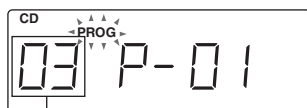

Track to be programmed

4 Press PROGRAM/CLOCK SET.

5 Repeat steps 3 and 4 to program other tracks.

6 Press PLAY/PAUSE ▶/|| while the PROG indicator blinks.

The tracks are played in the order you have programmed.

You can press CD PLAY/PAUSE on the remote control unit to start programmed playback.

Notes:

- If the PROG indicator goes off before you press PLAY/PAUSE ▶/|| (or CD PLAY/PAUSE on the remote control unit), press PROGRAM/CLOCK SET, then start playback.
- If you press CD/RANDOM while in CD mode, the unit enters the random playback mode.

To stop during playback

Press STOP ■ (or STOP on the remote control unit). The PROG indicator goes off and the unit exits from programmed playback.

To check the program contents

Before starting programmed playback, press PROGRAM/CLOCK SET.

Each time you press the button, the programmed tracks are shown in the display window.

To add tracks in the program

1 Press PROGRAM/CLOCK SET repeatedly so that "00" appears as the track number.

2 Press ◀◀ or ▶▶ to select the track number, then press PROGRAM/CLOCK SET.

To edit the program

1 Press PROGRAM/CLOCK SET repeatedly so that the program number you want to edit is shown.

2 Press ◀◀ or ▶▶ to select a new track number, then press PROGRAM/CLOCK SET.

To repeat programmed playback

Press PRESET + / CD REPEAT (or CD REPEAT / PRESET + on the remote control unit) after starting programmed playback.

To erase the entire program in the memory

Press PROGRAM/CLOCK SET so that the PROG indicator blinks, and press STOP ■ (or STOP on the remote control unit) while the PROG indicator blinks.

The stored program is also cleared when the disc door is opened.

Note:

After you have programmed 20 tracks, the program number returns to "1." Programming more tracks overwrite the tracks already programmed to those numbers.

Playing back introductions – Intro playback

Every track or every programmed track of a CD can be played for the beginning 10 seconds.

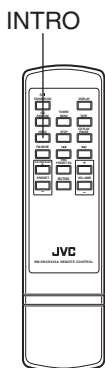

Press INTRO.

The INTRO indicator appears in the display window and intro playback starts.

To use intro playback for programmed and random playback, press the button after starting playback.

To stop during playback

Press STOP ■ (or STOP on the remote control unit).

The INTRO indicator goes off and the unit exits from the intro playback.

To cancel intro playback without stopping

Press INTRO during playback.

The INTRO indicator goes off and the unit continues playback.

Note:

If you press INTRO while playing a track over ten seconds from the beginning, the introduction of the next track begins to play.

Tuning in a station

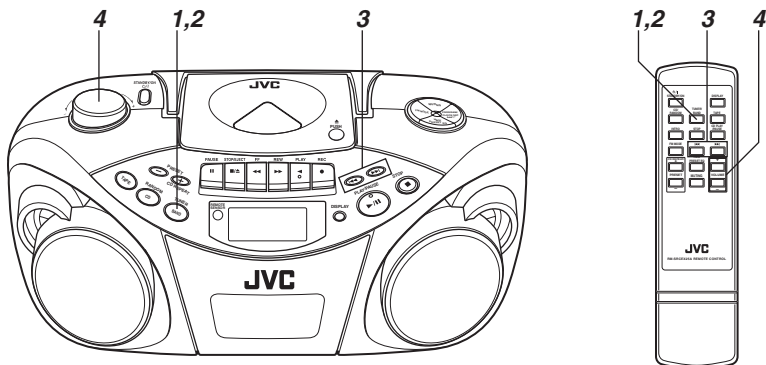

- 1** Press **BAND/TUNER** to enter the tuner mode.
- 2** Press **BAND/TUNER** to select the band, FM or AM.
- 3** Press and hold **◀◀** or **▶▶** for more than 1 second. The unit starts searching and stops when a station of sufficient signal strength is tuned in. If you press **◀◀** or **▶▶** briefly and repeatedly, the frequency changes step by step.
- 4** Adjust the volume.

Changing the FM reception mode

When an FM stereo broadcast is hard to receive or noisy, reception improves in monaural reception.

Press **FM MODE** so that the **MONO** indicator appears in the display window.

To restore the stereo effect, press **FM MODE** again so that the **MONO** indicator goes off.

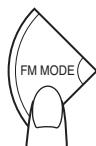

Main unit



Remote

Note:

The FM reception mode setting will be canceled when you tune in another station.

Using the antennas

FM

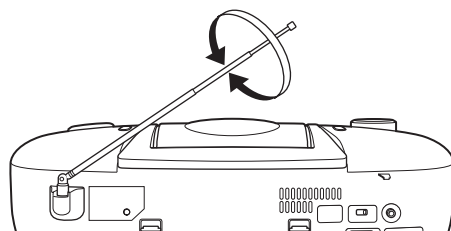

AM

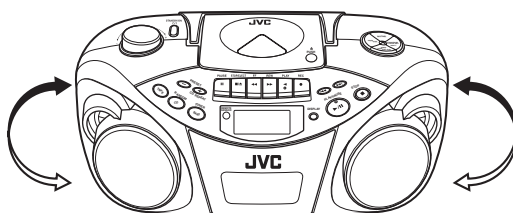

Note:

The built-in ferrite core antenna may pick up interference from television receivers in the neighborhood disturbing AM reception.

Presetting stations

You can preset 10 FM and 10 AM stations.

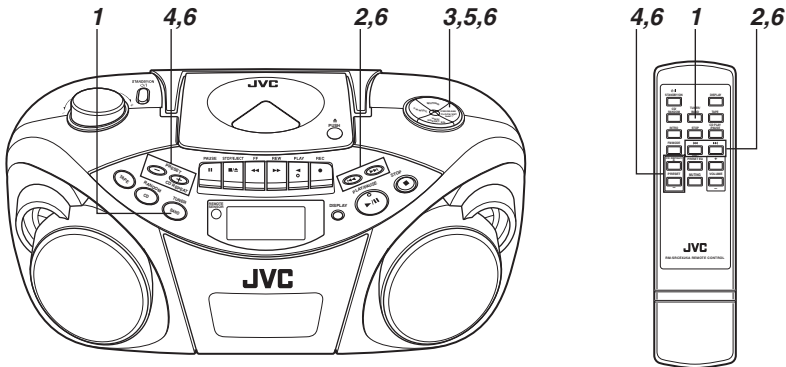

There is a time limit in doing the following steps. If the setting is canceled before you finish, start from step 3 again.

Note:

In some cases, test frequencies have been already memorized for the tuner since the factory examined the tuner preset function before shipment. This is not a malfunction. You can preset the stations you want into memory by following the presetting method.

- 1 Press BAND/TUNER to select the band, FM or AM.**
- 2 Press |◀◀ or ▶▶| to tune in the station you want to preset.**
- 3 Press PROGRAM/CLOCK SET.**

The PROG indicator starts blinking in the display window.

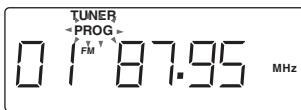

- 4 Press PRESET + / CD REPEAT or PRESET - to select the preset number.**

You can press CD REPEAT / PRESET + or PRESET - on the remote control unit to select the preset number.

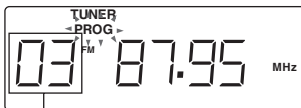

Preset number

- 5 Press PROGRAM/CLOCK SET.**

The tuned station in step 2 is stored in the preset number selected in step 4.

Storing a new station on a used number erases the previously stored one.

- 6 Repeat steps 2 to 5 to preset other stations, using different preset numbers.**

Tuning in a preset station

- 1 Press BAND/TUNER to select the band, FM or AM.**
- 2 Press PRESET + / CD REPEAT or PRESET - repeatedly until the desired preset number appears.**

Note:

If you unplug the AC power cord or if a power failure occurs, the preset stations will be erased in a few days. If this happens, preset the stations again.

CASSETTE PLAYBACK

Notes on cassette tapes

- Use only type-I normal tapes. The recording/playback characteristics of this unit are those for normal tapes, which have different characteristics from CrO₂ and metal tapes.
- The use of tapes longer than 120 minutes is not recommended, since characteristic deterioration may occur and these tapes easily jam in the pinch roller and the capstan.
- Loose tape may cause trouble. Gently tighten the tape with a pencil as shown in the figure below.

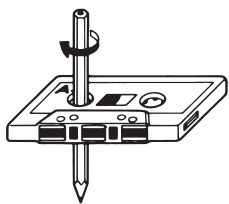

Turn the pencil to take up the slack.

- To prevent recordings from being accidentally erased, remove the tab(s) with a screwdriver. After the tabs have been broken off, reseal the slots with adhesive tape to erase or re-record.

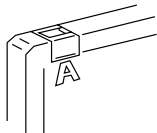

Loading a cassette

- 1 Press **STOP/EJECT** ■/▲ to open the cassette holder.
- 2 Load a cassette with the open side up and the playback side facing out as shown in the figure below.

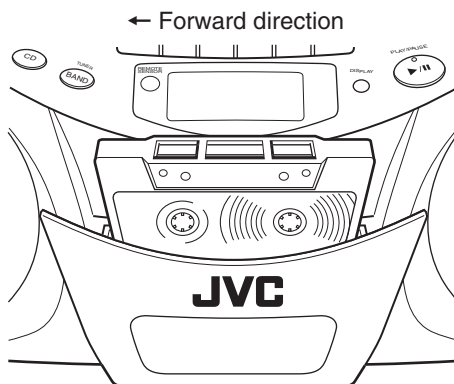

- 3 Close the cassette holder by pressing it gently and firmly.

The cassette holder clicks back into position.

Basic operation

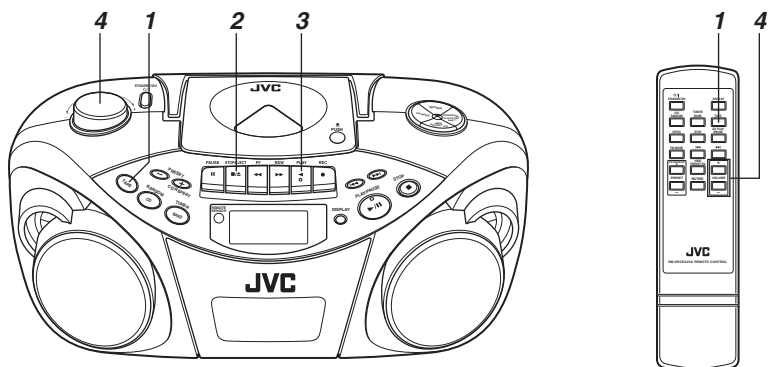

1 Press **TAPE** to enter the tape mode.

2 Load a cassette.

Use only a type-I normal tape.

3 Press **PLAY** ◀ to start playback.

4 Adjust the volume.

Fast-winding a tape

Press **REW** ▶▶ or **FF** ◀◀.

When the tape reaches the end, press **STOP/EJECT** ■/▲ to release **REW** ▶▶ or **FF** ◀◀.

To stop playback

Press **STOP/EJECT** ■/▲.

The tape also stops when it reaches the end.

Basic operation

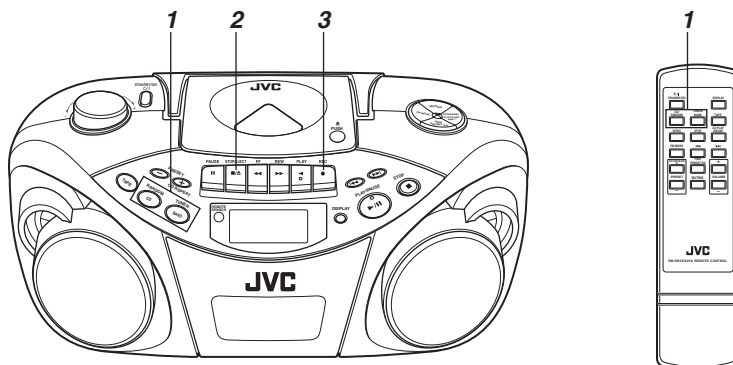

Standard recording

1 Prepare the recording source.

- When recording from the radio:
Set to the tuner mode and tune in a desired station.
- When recording from a CD:
Set to the CD mode and load a CD.

2 Load a blank or erasable cassette.

Use only a type-I normal tape.

3 Press REC ●.

PLAY ◀ is also depressed, and recording starts.

To stop recording

Press STOP/EJECT ■/▲.

The tape also stops when it reaches the end.

Notes:

- **It should be noted that it may be unlawful to re-record pre-recorded tapes, records, or discs without the consent of the owner of copyright in the sound or video recording, broadcast or cable program and in any literary, dramatic, musical, or artistic work embodied therein.**
- The recording level is automatically set correctly, so it is not affected by VOLUME. Thus, during recording you can adjust the sound you are actually listening to without affecting the recording level.
- If a recording you made has excessive noise or static, the unit may have been too close to a TV which was on during the recording. Either turn off the TV or increase the distance between the TV and the unit.

Using the beat-cut function

When recording an AM broadcast, beats may occur. If this happens, change the BEAT CUT switch on the rear of the unit to either "1" or "2" to reduce the beating sound.

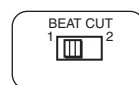

To start recording at the exact moment

- 1 Press PAUSE || first, then press REC ●, thus entering the record-pause (standby) mode.
- 2 Press PAUSE || to release the tape at the exact moment you want to start recording.

Note:

Do not leave the unit in pause mode for more than a few minutes. Instead, press STOP/EJECT ■/▲ to stop the tape.

Synchronized recording with CD playback

You can make the CD player to start playback when the tape deck enters the recording mode.

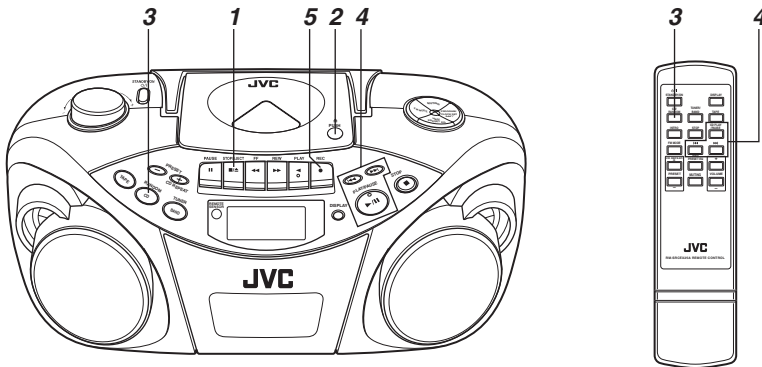

1 Load a cassette.

Use only a type-I normal tape.

2 Load a CD.

3 Press CD/RANDOM to enter CD mode.

You can press CD/RANDOM on the remote control unit to enter CD mode.

4 Specify a track or point on the disc to start recording.

- To start recording from the desired track, select the track by pressing **◀◀** or **▶▶** in stop mode.
- To start recording from the desired point on a disc, play the disc and pause at the desired point by pressing **▶/||** (or CD PLAY/PAUSE on the remote control unit).

5 Press REC ●.

PLAY ◀ is also depressed, and synchronized recording starts.

- The CD SYNC indicator appears in the display window during synchronized recording.

When the tape reaches the end first, the CD player enters the pause mode. Press **▶/||** (or CD PLAY/PAUSE on the remote control unit) to continue playback, or press **■** (or STOP on the remote control unit) to stop playback.

When the CD player stops first, the tape continues running. In this case, press **■/▲** to stop the tape.

Erasing

When recording on a pre-recorded tape, the previous recording is erased and only the new recording is heard next time the tape is played back.

To erase a tape without making a new recording

1 Press TAPE on the unit to enter the tape mode.

2 Press REC ●.

Cleaning the heads, capstan and pinch roller

Cleaning is important!

When the tape is running, magnetic powder and dust naturally accumulate on the heads, capstan and pinch roller. When they become too dirty;

- Sound quality deteriorates.
- The sound output level drops.
- The previous recording is not completely erased.
- Recording is not performed satisfactorily.

To avoid these, clean the heads, capstan and pinch roller every 10 hours of use.

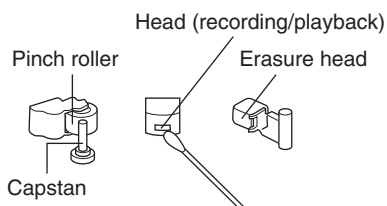

Open the cassette holder. Clean the heads, capstan and pinch roller.

For effective cleaning, use a cleaning kit available at an audio store.

After cleaning, make sure that the cleaning fluid has dried completely before loading a cassette.

Cautions:

- Keep magnets and metallic objects away from the head. If the head becomes magnetized, noise will increase and the sound will deteriorate.
- Demagnetize the recording/playback head every 20 to 30 hours of use with a head demagnetizer available at an audio store. When demagnetizing the head, the unit should be turned off.

As the erasure head of the unit is of magnetic type, do not demagnetize it.

- Do not use anything other than alcohol for cleaning. Thinner and benzine will damage the rubber pinch roller.

Cleaning the CD pickup lens

If the CD pickup lens is dirty, the sound may be degraded.

Open the disc door and clean the lens.

Use a blower (available at a camera store, etc.) to blow off dust on the lens.

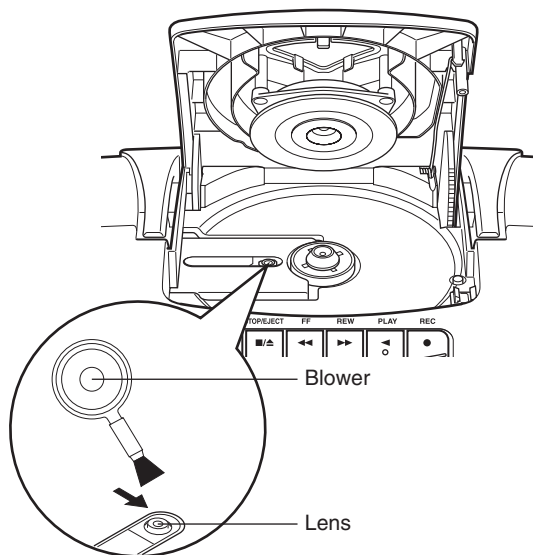

TROUBLESHOOTING

- If you are having a problem with your unit, check this list for a possible solution before calling for service.
- If you cannot solve the problem from the hints given here, or the unit has been physically damaged, call a qualified person, such as your dealer, for service.

Symptom	Possible cause	Action
Power cannot be turned on.	The power cord is unplugged.	Connect the power cord.
When PLAY ◀ is pressed, tape does not move.	PAUSE is pressed.	Press PAUSE again to release it.
Playback sound is at a very low level.	<ul style="list-style-type: none"> • Batteries are run down. • The head is dirty. 	<ul style="list-style-type: none"> • Replace the batteries with new ones. • Clean the head.
REC ● does not function.	<ul style="list-style-type: none"> • The safety tabs of the cassette have been broken off. • No cassette is loaded. 	<ul style="list-style-type: none"> • Reseal the slots with adhesive tape. • Load a cassette.
The disc is loaded but does not play.	<ul style="list-style-type: none"> • The disc is upside down. • The disc is dirty. • The disc is damaged or warped. • The lens is dirty. • There is moisture condensation. 	<ul style="list-style-type: none"> • Load the disc with the label side facing up. • Clean the disc. • Replace the disc with a playable one. • Clean the lens. • Turn the unit on and wait one or two hours before use.
No sound from the speakers.	Headphones are connected.	Disconnect the headphones.
Since the tape speed is irregular, wow and flutter occur.	<ul style="list-style-type: none"> • The pinch roller or capstan is dirty. • Batteries are run down. 	<ul style="list-style-type: none"> • Clean the pinch roller and capstan. • Replace the batteries with new ones.
Radio reception is poor and there is much static.	The antenna is not properly adjusted.	Adjust the antenna correctly.
Remote control is impossible.	<ul style="list-style-type: none"> • Batteries in the remote control unit are run down. • The remote sensor section is exposed to bright light (direct sunlight, etc.) 	<ul style="list-style-type: none"> • Replace the batteries with new ones. • Try not to operate the unit under direct sunlight, etc.

Note:

When the unit is moved from a cold place of around 0°C to a warm place, it may not operate normally, because moisture has formed inside the unit. Normal operation will be restored after waiting one or two hours.

Resetting the unit

If “TROUBLESHOOTING” does not eliminate malfunctioning (failure to operate or display properly, etc.), press the RESET button on the rear of the unit with something having a sharp point, while the unit is turned on.

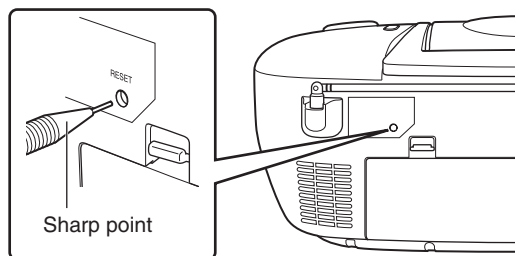

Note:

Resetting causes the unit to restore its factory default settings and results in all the settings made by the user being deleted.

SPECIFICATIONS

CD player

CD capacity	: 1 CD
Signal-to-noise ratio	: 75 dB
Dynamic range	: 60 dB

Tuner

Frequency range	: FM 87.5 – 108.0 MHz AM 522 – 1 629 kHz
Antennas	: Telescopic antenna for FM Ferrite core antenna for AM

Cassette deck

Frequency response	: 60 Hz – 10 000 Hz
Wow & flutter	: 0.15% (WRMS)
Fast wind time	: Approx. 150 sec. (C-60 cassette)

General

Speakers	: 9 cm cone × 2
Speaker impedance	: 4 Ω
Output power	: 4 W (2 W + 2 W) at 4 Ω (10% THD)
Output terminals	: PHONES × 1
Power supply	: AC 230 V \sim , 50 Hz DC 9 V (R20 (SUM-1)/D (13D)-size batteries × 6)
Power consumption	: 13 W (at operation) 3 W (on standby)
Dimensions	: 420 mm × 178 mm × 250 mm (W/H/D)
Mass	: Approx. 3.2 kg (without batteries)
Accessories provided	: AC power cord × 1 Remote control unit × 1 Batteries for the remote control unit (AAA/UM-4/ R03) × 2

Design and specifications are subject to change without notice.



JVC
VICTOR COMPANY OF JAPAN, LIMITED

JVC

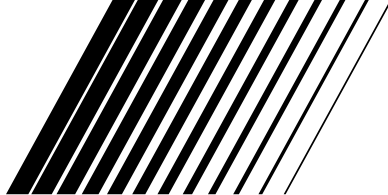

CD PORTABLE SYSTEM

BÄRBART CD-SYSTEM

KANNETTAVA CD-JÄRJESTELMÄ

BÆRBART CD-SYSTEM

RC-EX25S

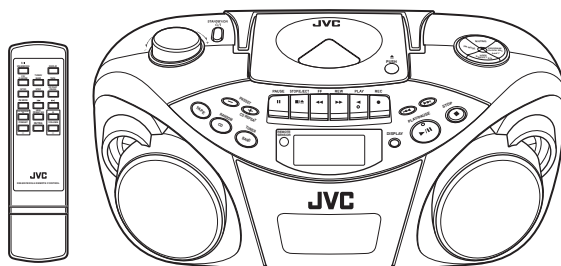

COMPACT
disc
DIGITAL AUDIO



INSTRUCTIONS

BRUKSANVISNING

KÄYTTÖOHJE

INSTRUKTIONSBOG

LVT1212-005A
[EN]

Warnings, Cautions and Others

Varningar, att observera och övrigt

Varoitukset, huomautukset, yms

Advarsler, forsigtighedsregler og andet

Caution — STANDBY/ON button!

Disconnect the mains plug to shut the power off completely. The STANDBY/ON button in any position does not disconnect the mains line.

Att observera — Nätströmknapp STANDBY/ON

Drag ut nätströmssladden för att stänga av strömmen helt. Strömbrytaren STANDBY/ON kopplar ej bort nätströmmen.

Huomautus — STANDBY/ON -näppäin!

Jos haluat katkaista laitteistosta virran kokonaan, irrota sähköpistoke seinäpistorasiasta. Virta on päällä kaikissa virtakytkimen(STANDBY/ON) asennoissa.

Forsigtig — STRØMAFBRYDER! (STANDBY/ON)

Tag netstikket ud for at afbryde strømtilførslen fuldstændigt. Med STANDBY/ON Strømafbryderen alene kan man ikke helt afbryde lysnetforbindelsen.

CAUTION

To reduce the risk of electrical shocks, fire, etc.:

1. Do not remove screws, covers or cabinet.
2. Do not expose this appliance to rain or moisture.

VIKTIGT

För att minska riskerna för elektriska stötar, brand, etc.:

1. Lossa into på skruvar, lock eller hölje.
2. Utsätt inte enheten för regn eller fukt.

VAROITUS

Vältä sähköiskun ja tulipalon vaara:

1. Älä avaa ruuveja tai koteloa.
2. Älä jätä laitetta sateeseen tai kosteaan paikkaan.

ADVARSEL

For at reducere faren for elektrisk stød, brand, etc.:

1. Fjern ikke skruer, dæksler eller kabinet.
 2. Udsæt ikke dette apparat for regn eller fugt.
-

CAUTION

- Do not block the ventilation openings or holes. (If the ventilation openings or holes are blocked by a newspaper or cloth, etc., the heat may not be able to get out.)
- Do not place any naked flame sources, such as lighted candles, on the apparatus.
- When discarding batteries, environmental problems must be considered and local rules or laws governing the disposal of these batteries must be followed strictly.
- Do not expose this apparatus to rain, moisture, dripping or splashing and that no objects filled with liquids, such as vases, shall be placed on the apparatus.

VIKTIGT

- Blockera inte ventilationsöppningarna på apparaten. (Om ventilationsöppningarna blockeras av en tidning, en duk eller liknande kan värme i apparaten eventuellt inte komma ut.)
- Placera ingenting med öppen låga, exempelvis ett tält ljus, på apparaten.
- Använda batterier måste handhas på ett miljömässigt korrekt sätt och de lagar och förordningar som gäller på platsen för begagnade batterier måste följas noga.
- Undvik att utsätta denna apparat för regn, fukt, droppand eller stänkande vätskor, och ställ ingenting med vatten i på den, exempelvis en vas.

VAROITUS

- Tuuletusrakoja tai -aukkoja ei saa tukkia. (Jos tuuletusraot tai -aukot tukitaan sanomalehdellä tai vaatteella yms., lämpö ei mahdollisesti pääse ulos.)
- Laitteen päälle ei saa asettaa avotulen lähteitä, kuten palavia kynttilöitä.
- Paristoja hävitettäessä on huomioitava ympäristöongelmat. Näiden paristojen hävitystä koskevia paikallisia määräyksiä ja lakeja on noudatettava ehdottomasti.
- Tätä laitetta ei saa altistaa sateelle, kosteudelle, veden tippumiselle tai roiskumiselle eikä laitteen päälle saa asettaa nesteellä täytettyjä esineitä, kuten kukkamaljakoita.

ADVARSEL

- Undgå at tilstoppe ventilationsåbningerne. (Hvis de tilstoppes af avispapir, en klud el.lign., vil varmen muligvis ikke kunne komme ud).
- Undlad at anbringe åben ild (f.eks. tændte stearinlys) oven på apparatet.
- Ved bortskaffelse af batterier bør de miljømæssige konsekvenser tages i betragtning, ligesom de relevante lokale bestemmelser nøje skal overholdes.
- Apparatet må ikke udsættes for regn, fugtighed, dryp eller stænk, ligesom der ikke bør anbringes beholdere med væske, f.eks. vaser, oven på apparatet.

IMPORTANT FOR LASER PRODUCTS

1. CLASS 1 LASER PRODUCT
2. **CAUTION:** Do not open the top cover. There are no user serviceable parts inside the unit; leave all servicing to qualified service personnel.
3. **CAUTION:** Visible and invisible laser radiation when open and interlock failed or defeated. Avoid direct exposure to beam.
4. **REPRODUCTION OF LABEL:** CAUTION LABEL, PLACED INSIDE THE UNIT.

ATT OBSERVERA ANGÅENDE LASERPRODUKTER

1. LASERPRODUKT AV KLASS 1
2. **VARNING:** Öppna inte det övre skyddet. Det finns inga delar inuti som användaren själv kan utföra service på; låt service utföras av utbildad servicepersonal.
3. **VARNING:** Synlig och osynlig laserstrålning när den öppnas och spärren är urkopplad. Betrakta ej strålen.
4. **REPRODUKTION AV ETIKETT:** VARNINGSETIKETT, PLACERAD PÅ APPARATENS INSIDA.

TÄRKEÄÄ TIETOA LASERTUOTTEISTA

1. LUOKAN 1 LASERLAITE
2. **VARO:** Älä avaa yläkantta. Laitteen sisällä ei ole käyttäjän huollettavia osia. Huollata laite valtuutetussa huoltoliikkeessä.
3. **VARO:** Avattaessa ja suojalukitus ohitettuna tai viallisena olet alttiina näkyvalle ja näkymättömälle lasersäteilylle. Vältä säteen kohdistumista suoraan itseesi.
4. **TARRAN TOISTO:** VAROITUSTARRA, SIJOITETAAN LAITTEEN SISÄPUOLELLE.

VIGTIGT FOR LASERPRODUKTER

1. KLASSE 1 LASER PRODUKT
2. **ADVARSEL:** Åbn ikke dækslet. Der findes ingen dele indeni apparatet som brugeren kan reparere. Overlad al service til kvalificeret servicepersonale.
3. **ADVARSEL:** Synlig og usynlig laserstråling når maskinen er åben eller interlocken fejler. Undgå direkte eksponering til stråling.
4. **REPRODUKTION AF ETIKETTE:** ADVARSELSETIKETTE, FINDES INDENI APPARATET.

CAUTION - INVISIBLE LASER RADIATION WHEN OPEN AND INTERLOCKS DEFEATED. AVOID EXPOSURE TO BEAM.

VORSICHT ! UNSICHTBARE LASERSTRAHLUNG TRITT AUS, WENN DECKEL GEÖFFNET UND WENN SICHERHEITVERRIEGELUNG ÜBERBRÜCKT IST. NICHT DEM STRAHL AUSSETZEN!

VARNING - OSYNLIG LASERSTRÅLNING NÄR DENNA DEL ÄR ÖPPNAD OCH SPÄRR ÄR URKOPPLAD STRÅLEN ÄR FARLIG.

ADVARSEL - USYNLIG LASERSTRÅLING VED ÅBNING NÄR SIKKERHEDSÅFBRYDERE ER UDE AF FUNKTION. UNGÅ UDSÆTTELSE FOR STRÅLING.

CONTENTS

FEATURES	1	ADJUSTING THE SOUND	8
SAFETY PRECAUTIONS	1	PLAYING COMPACT DISCS	9
HANDLING PRECAUTIONS	2	RADIO RECEPTION	14
POWER SUPPLY	3	CASSETTE PLAYBACK	16
NAMES OF PARTS AND CONTROLS	4	RECORDING	18
REMOTE CONTROL UNIT	5	MAINTENANCE	20
TURNING THE UNIT ON/OFF	6	TROUBLESHOOTING	21
SETTING THE CLOCK	7	SPECIFICATIONS	22

FEATURES

- 1 Portable system incorporating CD player**
 - CD functions can be operated with the remote control unit as well as on the main unit.
 - 8-cm CD playback capability
- 2 Digital LCD (Liquid Crystal Display) indicates general playback status.**
- 3 Synchronized recording with CD playback**
- 4 Hyper-Bass Sound effect**

SAFETY PRECAUTIONS

Prevention of Electric Shocks, Fire Hazards and Damages

- Even when the STANDBY/ON button is set to STANDBY, a very small current will flow. When the unit is turned on, the display window lights in orange. When the unit is in standby mode, the display window turns off. (Note, however, that the display window does not light even when the unit is turned on if the unit is operated on batteries.) To save power and for safety when not using the unit for an extended period of time, disconnect the power cord from the household AC outlet.
- Do not handle the power cord with wet hands.
- When unplugging from the wall outlet, always grasp and pull the plug, not the power cord.
- Consult your nearest dealer when damage, disconnection, or contact failure is found with the cord.
- Do not bend the cord sharply, or pull or twist it.
- Rating label is placed on the exterior of the bottom.
- Do not modify the power cord in any manner.
- Do not remove screws to disassemble the unit and do not touch anything inside the unit to avoid accidents.
- Do not insert any metallic objects into the unit.
- Unplug the power cord when there is a possibility of lightning.
- If water gets inside the unit, unplug the power cord from the outlet and consult your dealer.
- Do not block the ventilation holes of the unit so that heat can escape.
- Do not install the unit in a badly ventilated place.

HANDLING PRECAUTIONS

Do not use this unit in direct sunlight or leave the unit in a closed automobile (or yacht, etc.) where it would be exposed to high temperatures above 40°C.

1 Avoid using the unit in the following places:

- Where the temperature may become excessively high or low; the recommended temperature range is 5°C and 35°C.
- Where it could be subject to vibrations.
- Where it is excessively humid, such as in a bathroom.
- Where it could be magnetized by a magnet or speaker.

2 Pay attention to dust.

Be sure to close the disc door so that the lens is not contaminated by dust. Do not touch the lens.

3 Condensation

Condensation may occur in the following cases, in which the unit may not operate correctly:

- The unit is in a room where a heater has just been switched on.
- The unit is in a place where there is smoke or high humidity.
- The unit has just moved from a cold place to a warm room.

In these cases, set the STANDBY/ON button to ON and wait one or two hours before use.

4 Volume control

Compact discs produce very little noise compared with analog records. If you adjust the volume by listening to the noise as you do with analog records, the speakers could be damaged by a sudden blast of sound when playback starts. Therefore, turn down the volume before starting and adjust it as required while playing a CD.

5 Safety mechanism

The unit incorporates a safety interlock mechanism which switches off the laser beam when the disc door is opened.

6 Do not place magnetic objects such as cassette tapes near the speakers.

Since the speakers contain magnets inside, do not place cassette tapes or magnetic cards nearby as recorded data could be erased.

7 Keep the unit away from the TV.

When the unit is used near a TV, the TV picture could be distorted. If this happens, move the unit away from the TV. If this does not correct the situation, avoid using the unit when the TV is turned on.

8 Cleaning the cabinet

If the cabinet gets dirty, wipe it with a soft, dry cloth. Never use benzine or thinner as these could damage the surface finish.

9 When listening with headphones

- Do not listen at high volumes as it could damage your hearing.
- For safety, do not drive while listening with headphones.

10 Carrying handle

Do not raise or lower the carrying handle with the telescopic antenna extended, to avoid damaging the antenna. Position the carrying handle so that it does not interfere with operation.

POWER SUPPLY

Operation on household AC

Connect the AC power cord.

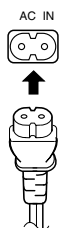

CAUTIONS:

- Use only with the JVC power cord provided with this unit to avoid malfunction or damage to the unit. Remove batteries when using the power cord.
- Be sure to unplug the power cord from the outlet when going out or when the unit is not in use for an extended period of time.

Operation on batteries

Loading batteries

1 Open the battery cover.

Pull the battery cover toward you while pressing the sections marked by the arrows.

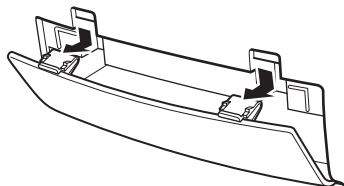

2 Insert six R20 (SUM-1)/D (13D)-size batteries.

Be sure to insert the batteries with the \oplus and \ominus terminals positioned correctly.

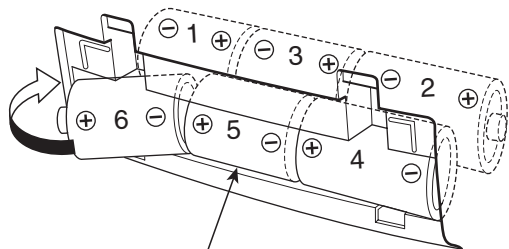

R20 (SUM-1)/D (13D)-size batteries

3 Replace the cover.

Checking batteries

When the tape speed or output sound level decreases, or CD playback becomes intermittent, replace all batteries with fresh ones.

When making an important recording, use new batteries (preferably alkaline batteries for a longer service life) to avoid any possible failure.

For better battery usage

- Continuous operation of the unit causes the battery power to be consumed more quickly than noncontinuous operation.
- Operation of the unit in a cold place causes the battery power to be consumed more quickly than in a warm place.

CAUTIONS:

- When not using the unit for a long time (more than two weeks) or when using the household AC, remove the batteries to avoid a malfunction or damage to the unit.
- When the JVC power cord provided with this unit is connected, the power is automatically switched from the batteries to the household AC even when the batteries are loaded.

However, remove the batteries when using the power cord.

CAUTIONS WHEN USING BATTERIES:

When batteries are used incorrectly, it may result in the leakage of chemicals from the batteries or they may explode. The following care should be taken:

- Check that the positive \oplus and negative \ominus terminals of the batteries are positioned correctly and load them as shown in the figure on the left.
- Do not mix new and old batteries together, or mix different types of batteries.
- Do not try to recharge non-rechargeable batteries.
- Remove the batteries when the unit is not to be used for an extended period of time.

If chemicals from the batteries come in contact with your skin, wash them off immediately with water. If chemicals leak onto the unit, clean the unit completely.

NAMES OF PARTS AND CONTROLS

Top and front sides

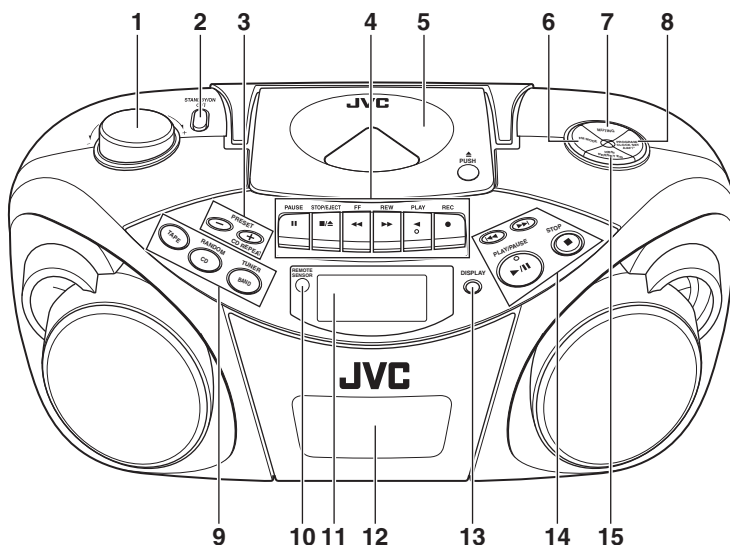

- | | |
|--|--|
| <p>1 VOLUME knob</p> <p>2 STANDBY/ON O/I button</p> <p>3 PRESET – button
PRESET + / CD REPEAT button</p> <p>4 Tape operation buttons
PAUSE II button
STOP/EJECT $\blacksquare/\blacktriangle$ button
FF \lll button
REW \ggg button
PLAY \blacktriangleleft button
REC \bullet button</p> <p>5 Disc door</p> <p>6 FM MODE button</p> <p>7 MUTING button</p> | <p>8 PROGRAM/CLOCK SET button</p> <p>9 TAPE button
CD/RANDOM button
BAND/TUNER button</p> <p>10 REMOTE SENSOR</p> <p>11 Display window</p> <p>12 Cassette deck</p> <p>13 DISPLAY button</p> <p>14 \lll button
\ggg button
PLAY/PAUSE $\blacktriangleleft/\text{II}$ button
STOP \blacksquare button</p> <p>15 HBS/PRESET EQ button</p> |
|--|--|

Rear side

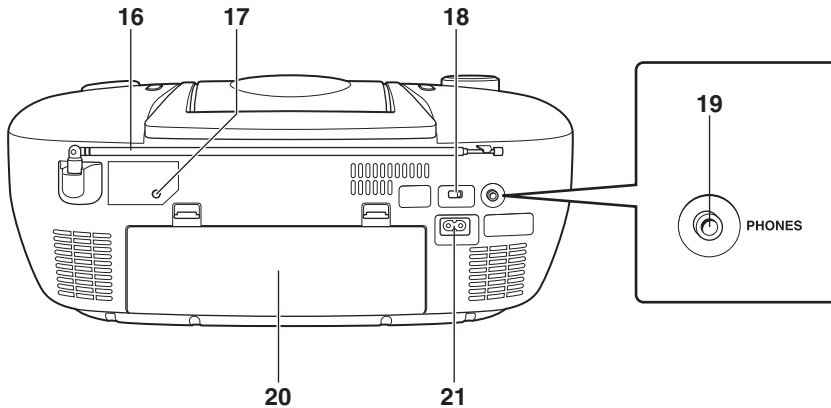

16 Telescopic antenna

17 RESET button

18 BEAT CUT switch

19 PHONES jack

Connect stereo mini headphones (3.5-mm diameters, impedance of 16 Ω to 32 Ω) to this jack. The speaker output is switched off with headphones connected.

20 Battery compartment cover

21 \sim AC IN (AC input) jack

REMOTE CONTROL UNIT

Installing batteries

1 Remove the battery cover from the back of the remote control unit.

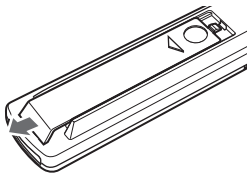

2 Insert two AAA (UM-4)/R03-size batteries (supplied).

Insert the batteries with the \oplus and \ominus terminals matching the indication inside the battery compartment. Insert the \ominus ends first.

AAA (UM-4)/R03-size batteries

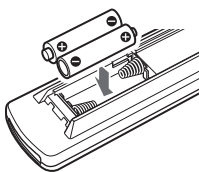

3 Replace the battery cover.

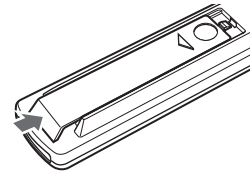

Battery replacement

The maximum operating distance between the remote control unit and the remote sensor section of the unit is approximately 7 meters. When the operating range decreases or remote control operation becomes unstable, replace the batteries with new ones.

Notes on using the remote control unit

- Point the top of the remote control unit toward the remote sensor section of the unit as directly as possible. The operable distance from the main unit decreases if you point the remote control unit at an angle.
- Press the buttons gently and firmly.
- Do not expose the remote sensor section of the unit to strong light (direct sunlight or artificial lighting) and make sure that there are no obstacles between the remote sensor section and the remote control unit.

Names of buttons

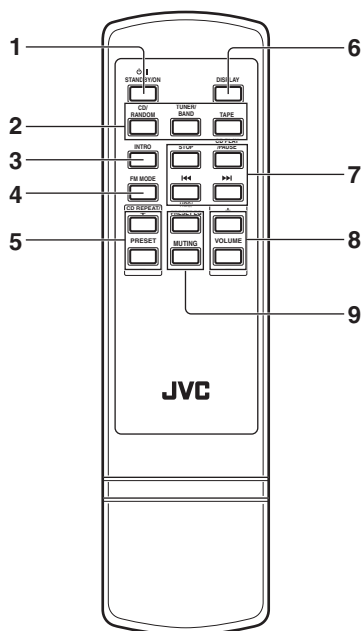

- 1 STANDBY/ON button
- 2 CD/RANDOM button
TUNER/BAND button
TAPE button
- 3 INTRO button
- 4 FM MODE button
- 5 CD REPEAT / PRESET + button
PRESET - button
- 6 DISPLAY button
- 7 STOP button
CD PLAY/PAUSE button
◀◀ button
▶▶ button
- 8 VOLUME + button
VOLUME - button
- 9 HBS/PRESET EQ button
MUTING button

TURNING THE UNIT ON/OFF

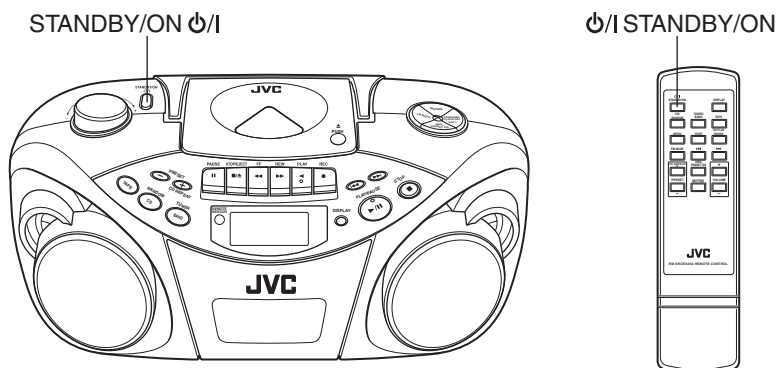

STANDBY/ON

STANDBY/ON button

Press the STANDBY/ON button on the unit to turn on and off the unit.

You can also press the STANDBY/ON button on the remote control unit.

The display window lights up when the unit is turned on. (Note, however, that the display window does not light even when the unit is turned on if the unit is operated on batteries.) The unit comes on ready to play the source selected when the unit was last turned off.

To switch off the power supply completely

Unplug the AC power cord from the AC outlet. If the batteries are inserted in the unit, take them out.

Notes:

- When you unplug the AC power cord or if a power failure occurs, the clock is reset to "0:00" right away, while the tuner preset stations (see page 15) will be erased in a few days. The clock indication will keep flashing until you set the clock again.
- Remove the batteries when carrying the unit by hand or in the trunk of a car. This prevents the power from being accidentally turned on, thus avoiding wasteful battery consumption.

SETTING THE CLOCK

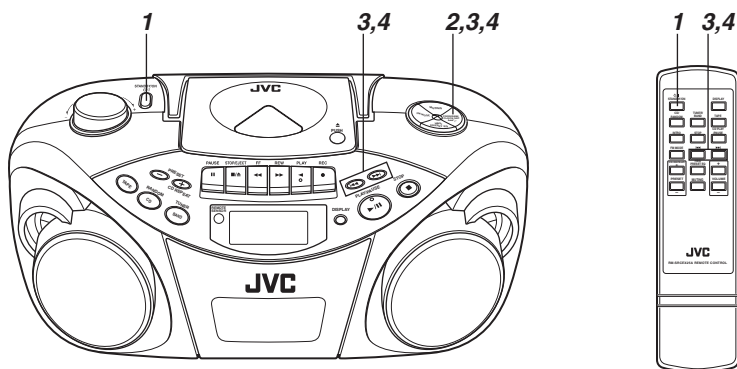

Before operating the unit any further, first set the clock built in this unit.

The clock uses 24-hour indication.

1 Press **STANDBY/ON** to turn off the unit, if it is turned on.

The clock flashes on the display window.

2 Press and hold **PROGRAM/CLOCK SET** for more than 2 seconds.

The hour digits start flashing.



3 Press **◀◀** or **▶▶** to adjust the hour, then press **PROGRAM/CLOCK SET**.

The minute digits start flashing.



4 Press **◀◀** or **▶▶** to adjust the minutes, then press **PROGRAM/CLOCK SET**.

Note:

If there is a power failure, the clock loses the setting and is reset to "0:00." The clock indication will keep flashing until you set the clock again.

To show the clock when CD or tuner is selected

Press **DISPLAY**.

Each time you press the button, the display changes the clock indication and the normal indication alternately. (Operating the unit while clock indication is displayed changes the display to the normal indication.)



Main unit



Remote

ADJUSTING THE SOUND

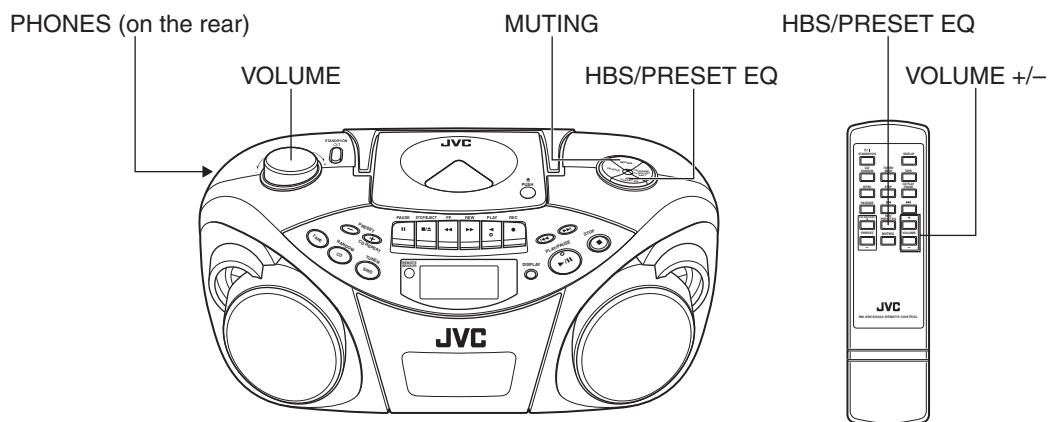

Adjusting the volume

Turn **VOLUME** clockwise to increase the volume or counterclockwise to decrease it.

You can press **VOLUME +** or **VOLUME -** on the remote control unit to increase or decrease the volume respectively.

The volume level can be adjusted in 31 steps (00 VOL to 30 VOL).



Caution:

DO NOT turn off the unit with the volume set to an extremely high level; otherwise a sudden blast of sound could damage your hearing and/or the speakers and headphones, when you turn on the unit or start playing another source next time.

REMEMBER you cannot adjust the volume unless the unit is turned on.

Turning off the sound temporarily

During playback, press **MUTING**.

The sound is turned off and the **MUTING** indicator appears in the display window.

To restore the sound, press **MUTING** again.

Listening through headphones

Connect a pair of headphones to the **PHONES** jack.

No sound comes out of the speakers anymore. Be sure to turn down the volume before connecting headphones.

Reinforcing the bass sound

You can enjoy powerful bass sound with the Hyper-Bass Sound effect.

Press and hold **HBS/PRESET EQ** so that the **HBS** indicator lights up in the display window.

To turn off the effect, press and hold the button again so that the **HBS** indicator goes off.

Selecting the sound mode

You can select one of the 5 preset sound modes.

CLASSIC: Good for classical music.

ROCK : Boosts low and high frequency. Good for acoustic music.

POP : Good for vocal music.

JAZZ : Good for jazz music.

FLAT : Normal sound.

To select the sound mode

Press **HBS/PRESET EQ** repeatedly until the indicator for the sound mode you want appears in the display window.

Each time you press the button, the sound mode changes as follows:



PLAYING COMPACT DISCS

Notes on compact discs

This unit has been designed only to play back the following CDs.

- Digital audio CD
- Recordable digital audio CD (CD-R)
- Rewritable digital audio CD (CD-RW)



When playing a CD-R or CD-RW

You can play back **finalized CD-R or CD-RW** recorded in **music CD format**. (If a CD-RW has been recorded in a different format, erase all the data on the CD-RW completely before recording on it.)

- You can play back CD-R or CD-RW like an audio CD.
- Some CD-R or CD-RW may not be played back on this unit because of their disc characteristics, damage or stain on them, or if the player lens is dirty.
- The reflection factor of CD-RW is lower than that of other CDs, possibly causing CD-RW to take longer time to read.
- CD-R and CD-RW of MP3 format cannot be played back.

Handling discs

Since dirty, damaged or warped discs could damage the unit, care should be taken of the following:

- Do not touch the reflective recorded surface.
- Do not stick or write anything on the label side.
- Do not bend discs.

Storage

- After removing a disc from the unit, be sure to put it back in its case.
- Do not expose discs to direct sunlight, high temperatures from a heater, etc., high humidity or dust.

Cleaning discs

Before loading a disc, wipe off any dust, dirt or fingerprints with a soft, dry cloth. Discs should be cleaned by wiping radially, from the center to edge.

Never use thinner, benzene, record cleaner or antistatic spray.

- Removing the disc from its storage case and replacing it

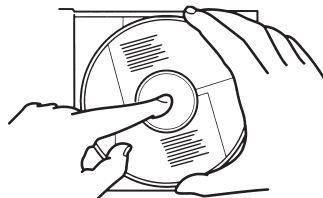

Press the center and lift out.

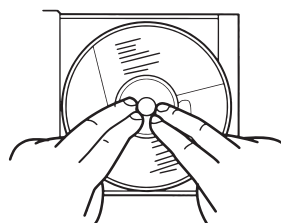

Press to secure the disc.

- Handling

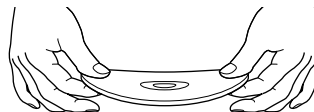

Incorrect

- Cleaning



Correct



Incorrect

Basic operation

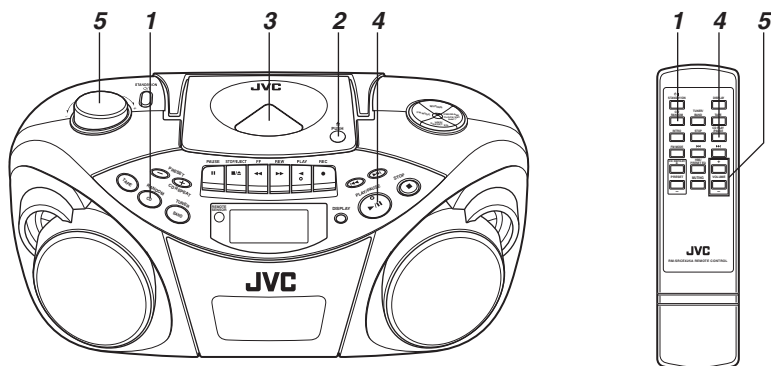

1 Press CD/RANDOM to enter CD mode, if the unit is in TUNER or TAPE mode.

You can press CD/RANDOM on the remote control unit to enter CD mode.

2 Press \triangle PUSH to open the disc door.

3 Load a disc with the label side facing up and close the disc door.

- 8-cm CD can be played on the unit without an adapter.

4 Press PLAY/PAUSE \blacktriangleright /II to start playback.

You can start playback by pressing CD PLAY/PAUSE on the remote control unit.

The current track number and elapsed playing time are displayed during playback.



5 Adjust the volume.

Notes:

- The following indication may be displayed when the disc is loaded upside down. Reload the disc correctly.

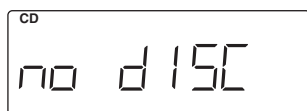

- If mistracking occurs during playback, lower the volume.
- Mistracking may occur if a strong shock is applied to the unit or if it is used in a place subject to vibrations (e.g. in a car travelling on a rough road).
- If you press CD/RANDOM while in CD mode, the unit enters the random playback mode.

To stop playback

Press STOP \blacksquare .

You can press STOP on the remote control unit to stop playback.



Main unit



Remote

Caution:

Stop playback before opening the disc door. Check that the disc has completely stopped rotating before unloading the disc.

To pause playback

Press PLAY/PAUSE \blacktriangleright /II during playback.

You can press CD PLAY/PAUSE on the remote control unit to pause playback.

To resume playback, press the button again.



Main unit

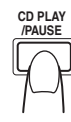

Remote

Skipping

- **To skip back to the previous track**

During playback, press **⏮** once to return to the beginning of the current track, press twice to skip back to the beginning of the previous track.

- **To skip to the next track**

During playback, press **⏭** to skip to the beginning of the next track.

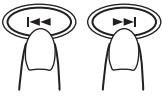

Main unit

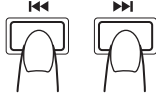

Remote

Search – locating a desired position on the disc

Press and hold **⏮ or **⏭** during playback.**

Monitor the sound and release the button when the desired position is located.

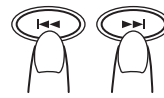

Main unit

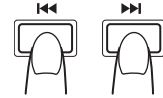

Remote

Repeat/Random playback

CD/RANDOM PRESET+/CD REPEAT

CD REPEAT/PRESET + CD/RANDOM

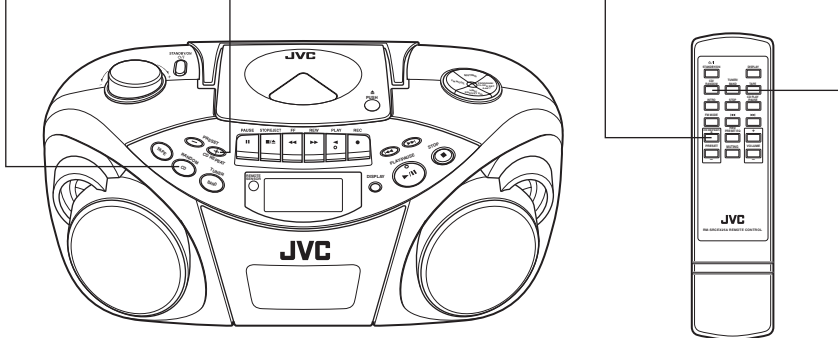

Repeat playback

Press PRESET + / CD REPEAT during playback.

You can press CD REPEAT / PRESET + on the remote control unit to select repeat playback.

Each time you press the button, the repeat mode changes in the following order:

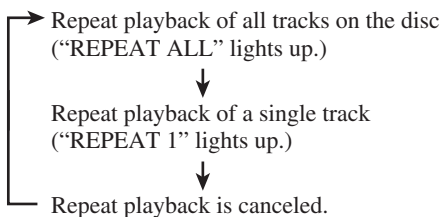

Random playback

Press CD/RANDOM in CD mode so that the RANDOM indicator lights up in the display window.

You can press CD/RANDOM on the remote control unit to select random playback.

Tracks are played in random order.

To cancel random playback, press the button again so that the RANDOM indicator goes off.

Programmed playback

Up to 20 tracks can be programmed to play in any desired order.

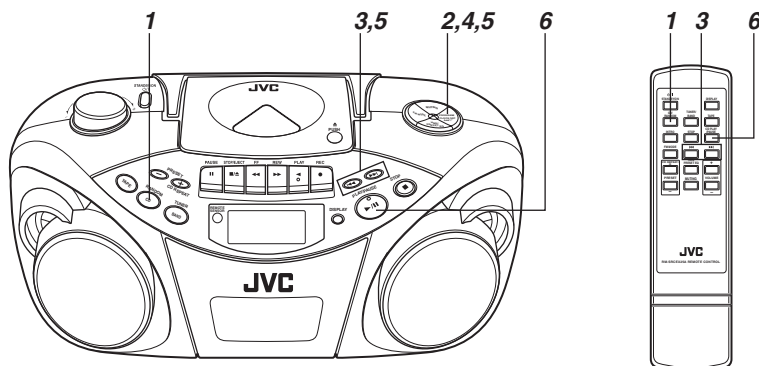

Note:

There is a time limit in doing the following steps. If the setting is canceled before you finish, start from step 2 again.

1 Press CD/RANDOM to enter CD mode.

You can press CD/RANDOM on the remote control unit to enter CD mode.

2 Press PROGRAM/CLOCK SET in stop mode.

The PROG indicator starts blinking in the display window.

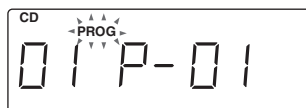

3 Press ◀◀ or ▶▶ to select a desired track to be programmed.

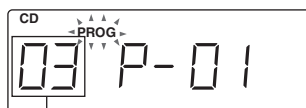

Track to be programmed

4 Press PROGRAM/CLOCK SET.

5 Repeat steps 3 and 4 to program other tracks.

6 Press PLAY/PAUSE ▶/|| while the PROG indicator blinks.

The tracks are played in the order you have programmed.

You can press CD PLAY/PAUSE on the remote control unit to start programmed playback.

Notes:

- If the PROG indicator goes off before you press PLAY/PAUSE ▶/|| (or CD PLAY/PAUSE on the remote control unit), press PROGRAM/CLOCK SET, then start playback.
- If you press CD/RANDOM while in CD mode, the unit enters the random playback mode.

To stop during playback

Press STOP ■ (or STOP on the remote control unit). The PROG indicator goes off and the unit exits from programmed playback.

To check the program contents

Before starting programmed playback, press PROGRAM/CLOCK SET.

Each time you press the button, the programmed tracks are shown in the display window.

To add tracks in the program

1 Press PROGRAM/CLOCK SET repeatedly so that "00" appears as the track number.

2 Press ◀◀ or ▶▶ to select the track number, then press PROGRAM/CLOCK SET.

To edit the program

1 Press PROGRAM/CLOCK SET repeatedly so that the program number you want to edit is shown.

2 Press ◀◀ or ▶▶ to select a new track number, then press PROGRAM/CLOCK SET.

To repeat programmed playback

Press PRESET + / CD REPEAT (or CD REPEAT / PRESET + on the remote control unit) after starting programmed playback.

To erase the entire program in the memory

Press PROGRAM/CLOCK SET so that the PROG indicator blinks, and press STOP ■ (or STOP on the remote control unit) while the PROG indicator blinks.

The stored program is also cleared when the disc door is opened.

Note:

After you have programmed 20 tracks, the program number returns to "1." Programming more tracks overwrite the tracks already programmed to those numbers.

Playing back introductions – Intro playback

Every track or every programmed track of a CD can be played for the beginning 10 seconds.

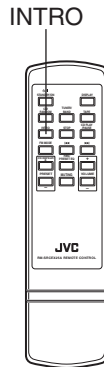

Press INTRO.

The INTRO indicator appears in the display window and intro playback starts.

To use intro playback for programmed and random playback, press the button after starting playback.

To stop during playback

Press STOP ■ (or STOP on the remote control unit).

The INTRO indicator goes off and the unit exits from the intro playback.

To cancel intro playback without stopping

Press INTRO during playback.

The INTRO indicator goes off and the unit continues playback.

Note:

If you press INTRO while playing a track over ten seconds from the beginning, the introduction of the next track begins to play.

Tuning in a station

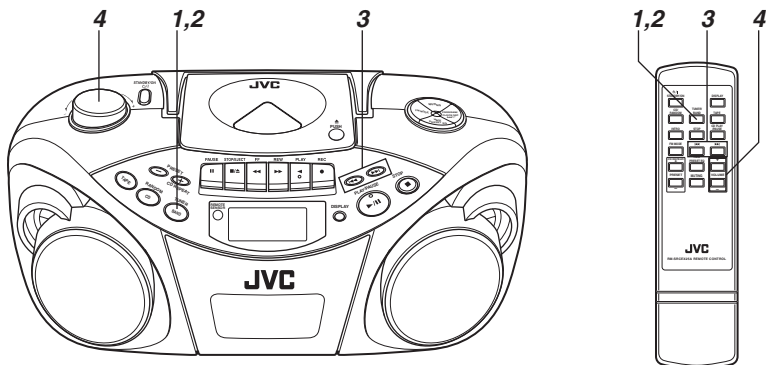

- 1** Press **BAND/TUNER** to enter the tuner mode.
- 2** Press **BAND/TUNER** to select the band, FM or AM.
- 3** Press and hold **◀◀** or **▶▶** for more than 1 second. The unit starts searching and stops when a station of sufficient signal strength is tuned in. If you press **◀◀** or **▶▶** briefly and repeatedly, the frequency changes step by step.
- 4** Adjust the volume.

Changing the FM reception mode

When an FM stereo broadcast is hard to receive or noisy, reception improves in monaural reception.

Press **FM MODE** so that the **MONO** indicator appears in the display window.

To restore the stereo effect, press **FM MODE** again so that the **MONO** indicator goes off.



Main unit



Remote

Note:

The FM reception mode setting will be canceled when you tune in another station.

Using the antennas

FM

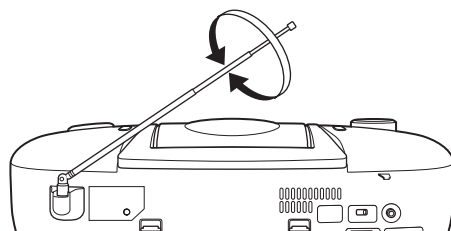

AM

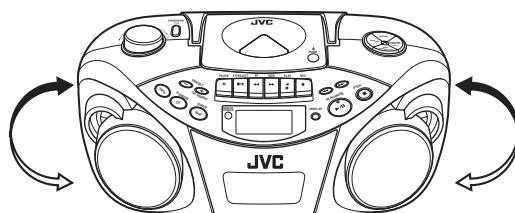

Note:

The built-in ferrite core antenna may pick up interference from television receivers in the neighborhood disturbing AM reception.

Presetting stations

You can preset 10 FM and 10 AM stations.

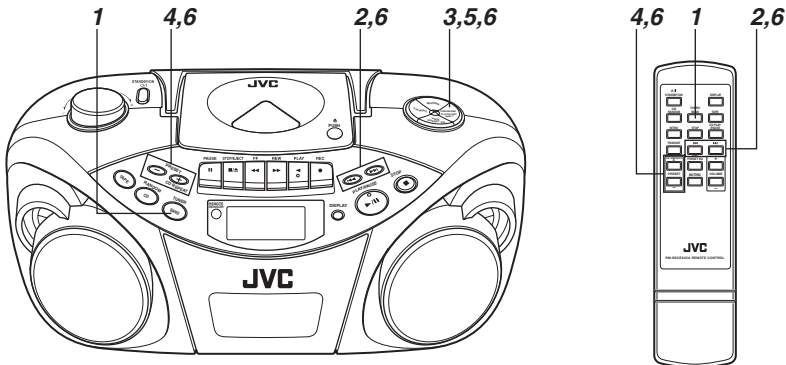

There is a time limit in doing the following steps. If the setting is canceled before you finish, start from step 3 again.

Note:

In some cases, test frequencies have been already memorized for the tuner since the factory examined the tuner preset function before shipment. This is not a malfunction. You can preset the stations you want into memory by following the presetting method.

- 1 Press BAND/TUNER to select the band, FM or AM.**
- 2 Press |◀◀ or ▶▶| to tune in the station you want to preset.**
- 3 Press PROGRAM/CLOCK SET.**

The PROG indicator starts blinking in the display window.

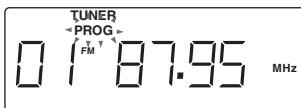

- 4 Press PRESET + / CD REPEAT or PRESET - to select the preset number.**

You can press CD REPEAT / PRESET + or PRESET - on the remote control unit to select the preset number.

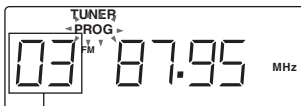

Preset number

- 5 Press PROGRAM/CLOCK SET.**

The tuned station in step 2 is stored in the preset number selected in step 4.

Storing a new station on a used number erases the previously stored one.

- 6 Repeat steps 2 to 5 to preset other stations, using different preset numbers.**

Tuning in a preset station

- 1 Press BAND/TUNER to select the band, FM or AM.**
- 2 Press PRESET + / CD REPEAT or PRESET - repeatedly until the desired preset number appears.**

Note:

If you unplug the AC power cord or if a power failure occurs, the preset stations will be erased in a few days. If this happens, preset the stations again.

Notes on cassette tapes

- Use only type-I normal tapes. The recording/playback characteristics of this unit are those for normal tapes, which have different characteristics from CrO₂ and metal tapes.
- The use of tapes longer than 120 minutes is not recommended, since characteristic deterioration may occur and these tapes easily jam in the pinch roller and the capstan.
- Loose tape may cause trouble. Gently tighten the tape with a pencil as shown in the figure below.

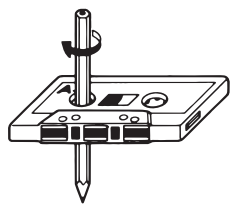

Turn the pencil to take up the slack.

- To prevent recordings from being accidentally erased, remove the tab(s) with a screwdriver. After the tabs have been broken off, reseal the slots with adhesive tape to erase or re-record.

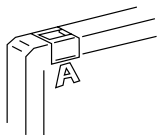

Loading a cassette

- 1 Press STOP/EJECT ■/▲ to open the cassette holder.**
- 2 Load a cassette with the open side up and the playback side facing out as shown in the figure below.**

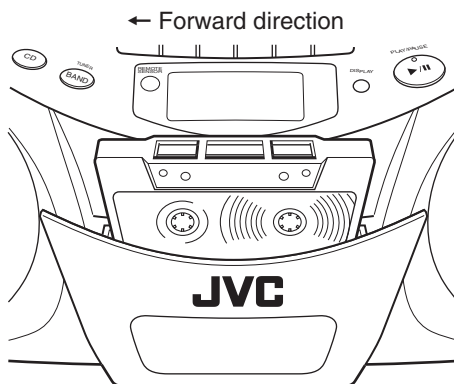

- 3 Close the cassette holder by pressing it gently and firmly.**

The cassette holder clicks back into position.

Basic operation

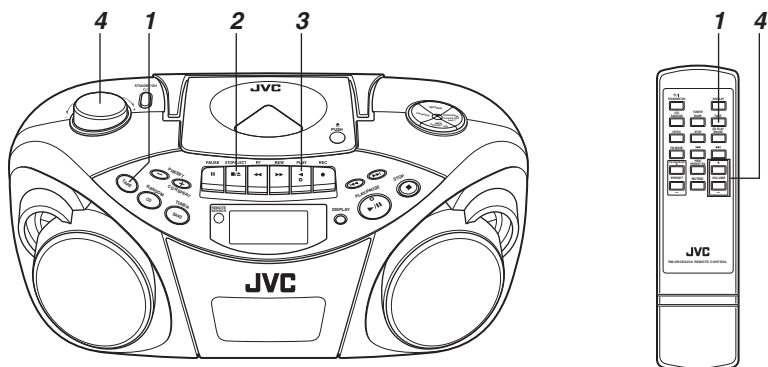

1 Press **TAPE** to enter the tape mode.

2 Load a cassette.

Use only a type-I normal tape.

3 Press **PLAY** ◀ to start playback.

4 Adjust the volume.

To stop playback

Press **STOP/EJECT** ■/▲.

The tape also stops when it reaches the end.

Fast-winding a tape

Press **REW** ▶▶ or **FF** ◀◀.

When the tape reaches the end, press **STOP/EJECT** ■/▲ to release **REW** ▶▶ or **FF** ◀◀.

Basic operation

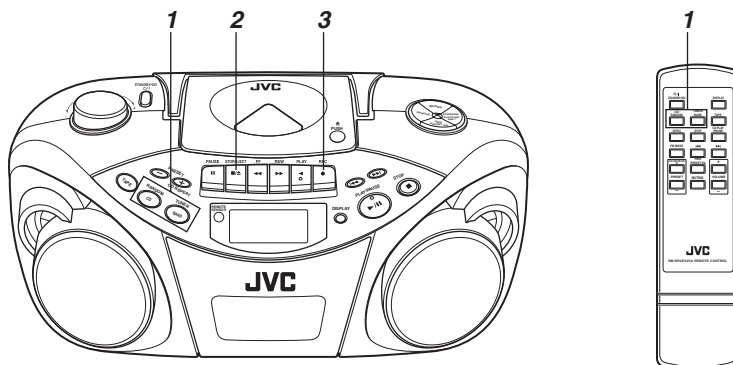

Standard recording

1 Prepare the recording source.

- When recording from the radio:
Set to the tuner mode and tune in a desired station.
- When recording from a CD:
Set to the CD mode and load a CD.

2 Load a blank or erasable cassette.

Use only a type-I normal tape.

3 Press REC ●.

PLAY ◀ is also depressed, and recording starts.

To stop recording

Press STOP/EJECT ■/▲.

The tape also stops when it reaches the end.

Notes:

- **It should be noted that it may be unlawful to re-record pre-recorded tapes, records, or discs without the consent of the owner of copyright in the sound or video recording, broadcast or cable program and in any literary, dramatic, musical, or artistic work embodied therein.**
- The recording level is automatically set correctly, so it is not affected by VOLUME. Thus, during recording you can adjust the sound you are actually listening to without affecting the recording level.
- If a recording you made has excessive noise or static, the unit may have been too close to a TV which was on during the recording. Either turn off the TV or increase the distance between the TV and the unit.

Using the beat-cut function

When recording an AM broadcast, beats may occur. If this happens, change the BEAT CUT switch on the rear of the unit to either “1” or “2” to reduce the beating sound.

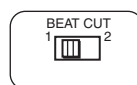

To start recording at the exact moment

- 1 Press PAUSE || first, then press REC ●, thus entering the record-pause (standby) mode.
- 2 Press PAUSE || to release the tape at the exact moment you want to start recording.

Note:

Do not leave the unit in pause mode for more than a few minutes. Instead, press STOP/EJECT ■/▲ to stop the tape.

Synchronized recording with CD playback

You can make the CD player to start playback when the tape deck enters the recording mode.

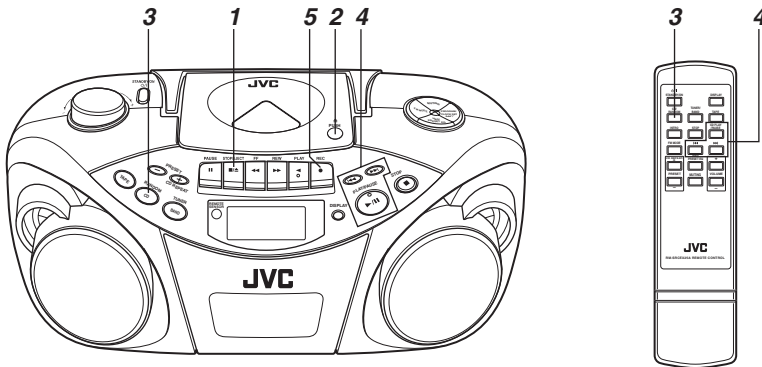

1 Load a cassette.

Use only a type-I normal tape.

2 Load a CD.

3 Press CD/RANDOM to enter CD mode.

You can press CD/RANDOM on the remote control unit to enter CD mode.

4 Specify a track or point on the disc to start recording.

- To start recording from the desired track, select the track by pressing **◀◀** or **▶▶** in stop mode.
- To start recording from the desired point on a disc, play the disc and pause at the desired point by pressing **▶/||** (or CD PLAY/PAUSE on the remote control unit).

5 Press REC ●.

PLAY ◀ is also depressed, and synchronized recording starts.

- The CD SYNC indicator appears in the display window during synchronized recording.

When the tape reaches the end first, the CD player enters the pause mode. Press **▶/||** (or CD PLAY/PAUSE on the remote control unit) to continue playback, or press **■** (or STOP on the remote control unit) to stop playback.

When the CD player stops first, the tape continues running. In this case, press **■/▲** to stop the tape.

Erasing

When recording on a pre-recorded tape, the previous recording is erased and only the new recording is heard next time the tape is played back.

To erase a tape without making a new recording

1 Press **TAPE** on the unit to enter the tape mode.

2 Press **REC ●**.

MAINTENANCE

Cleaning the heads, capstan and pinch roller

Cleaning is important!

When the tape is running, magnetic powder and dust naturally accumulate on the heads, capstan and pinch roller. When they become too dirty;

- Sound quality deteriorates.
- The sound output level drops.
- The previous recording is not completely erased.
- Recording is not performed satisfactorily.

To avoid these, clean the heads, capstan and pinch roller every 10 hours of use.

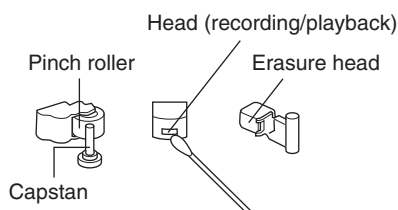

Open the cassette holder. Clean the heads, capstan and pinch roller.

For effective cleaning, use a cleaning kit available at an audio store.

After cleaning, make sure that the cleaning fluid has dried completely before loading a cassette.

Cautions:

- Keep magnets and metallic objects away from the head. If the head becomes magnetized, noise will increase and the sound will deteriorate.
- Demagnetize the recording/playback head every 20 to 30 hours of use with a head demagnetizer available at an audio store. When demagnetizing the head, the unit should be turned off.

As the erasure head of the unit is of magnetic type, do not demagnetize it.

- Do not use anything other than alcohol for cleaning. Thinner and benzine will damage the rubber pinch roller.

Cleaning the CD pickup lens

If the CD pickup lens is dirty, the sound may be degraded.

Open the disc door and clean the lens.

Use a blower (available at a camera store, etc.) to blow off dust on the lens.

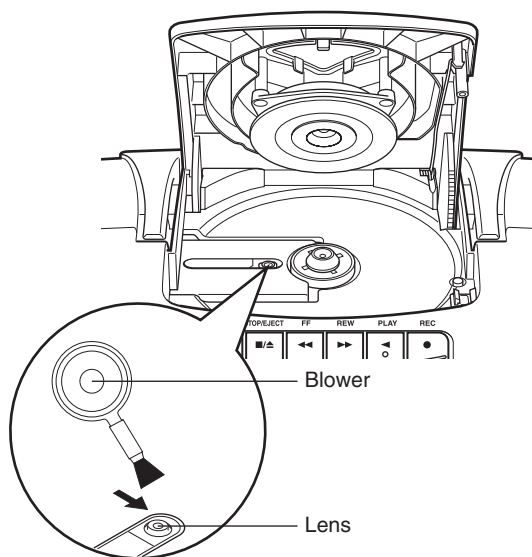

TROUBLESHOOTING

- If you are having a problem with your unit, check this list for a possible solution before calling for service.
- If you cannot solve the problem from the hints given here, or the unit has been physically damaged, call a qualified person, such as your dealer, for service.

Symptom	Possible cause	Action
Power cannot be turned on.	The power cord is unplugged.	Connect the power cord.
When PLAY ◀ is pressed, tape does not move.	PAUSE is pressed.	Press PAUSE again to release it.
Playback sound is at a very low level.	<ul style="list-style-type: none"> • Batteries are run down. • The head is dirty. 	<ul style="list-style-type: none"> • Replace the batteries with new ones. • Clean the head.
REC ● does not function.	<ul style="list-style-type: none"> • The safety tabs of the cassette have been broken off. • No cassette is loaded. 	<ul style="list-style-type: none"> • Reseal the slots with adhesive tape. • Load a cassette.
The disc is loaded but does not play.	<ul style="list-style-type: none"> • The disc is upside down. • The disc is dirty. • The disc is damaged or warped. • The lens is dirty. • There is moisture condensation. 	<ul style="list-style-type: none"> • Load the disc with the label side facing up. • Clean the disc. • Replace the disc with a playable one. • Clean the lens. • Turn the unit on and wait one or two hours before use.
No sound from the speakers.	Headphones are connected.	Disconnect the headphones.
Since the tape speed is irregular, wow and flutter occur.	<ul style="list-style-type: none"> • The pinch roller or capstan is dirty. • Batteries are run down. 	<ul style="list-style-type: none"> • Clean the pinch roller and capstan. • Replace the batteries with new ones.
Radio reception is poor and there is much static.	The antenna is not properly adjusted.	Adjust the antenna correctly.
Remote control is impossible.	<ul style="list-style-type: none"> • Batteries in the remote control unit are run down. • The remote sensor section is exposed to bright light (direct sunlight, etc.) 	<ul style="list-style-type: none"> • Replace the batteries with new ones. • Try not to operate the unit under direct sunlight, etc.

Note:

When the unit is moved from a cold place of around 0°C to a warm place, it may not operate normally, because moisture has formed inside the unit. Normal operation will be restored after waiting one or two hours.

Resetting the unit

If “TROUBLESHOOTING” does not eliminate malfunctioning (failure to operate or display properly, etc.), press the RESET button on the rear of the unit with something having a sharp point, while the unit is turned on.

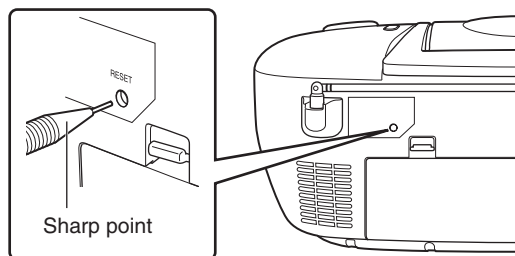

Note:

Resetting causes the unit to restore its factory default settings and results in all the settings made by the user being deleted.

SPECIFICATIONS

CD player

CD capacity	: 1 CD
Signal-to-noise ratio	: 75 dB
Dynamic range	: 60 dB

Tuner

Frequency range	: FM 87.5 – 108.0 MHz AM 522 – 1 629 kHz
Antennas	: Telescopic antenna for FM Ferrite core antenna for AM

Cassette deck

Frequency response	: 60 Hz – 10 000 Hz
Wow & flutter	: 0.15% (WRMS)
Fast wind time	: Approx. 150 sec. (C-60 cassette)

General

Speakers	: 9 cm cone × 2
Speaker impedance	: 4 Ω
Output power	: 4 W (2 W + 2 W) at 4 Ω (10% THD)
Output terminals	: PHONES × 1
Power supply	: AC 230 V ~, 50 Hz DC 9 V (R20 (SUM-1)/D (13D)-size batteries × 6)
Power consumption	: 13 W (at operation) 3 W (on standby)
Dimensions	: 420 mm × 178 mm × 250 mm (W/H/D)
Mass	: Approx. 3.2 kg (without batteries)
Accessories provided	: AC power cord × 1 Remote control unit × 1 Batteries for the remote control unit (AAA/UM-4/ R03) × 2

Design and specifications are subject to change without notice.



JVC
VICTOR COMPANY OF JAPAN, LIMITED